



General Purpose Input/Output (GPIO) Module
Programmer's Reference Manual

Thermal Series Printers

Product Warranty

Printronix Auto ID Technology, Inc warrants to the purchaser that under normal use and service, this printer (excluding the thermal printhead) purchased hereunder shall be free from defects in material and workmanship for a period of one year from the date of shipment from Printronix. In the United States and Canada, the printer warranty provides a 1-year return-to-factory warranty which commences on the date of shipment from Printronix. Costs of shipping to be borne by the purchaser.

Consumable items such as media and ribbons are not covered under this warranty. This warranty does not cover equipment or parts that have been misused, altered, or used for purposes other than those for which they were manufactured. This warranty also does not cover loss, shipping damage, damage resulting from accident or damages resulting from unauthorized service.

The Products may be equipped with a general purpose input/output circuit board and corresponding pin connection (GPIO) which allow the Purchaser's or end user's printer to function as a controller in a computer system.

Printronix Auto ID Technology publishes the specifications associated with GPIO and the pin connection and warrants that the printer's input and output parameters at the pin connection conform to those specifications. Except as expressly warranted, GPIO is sold on an "as is" basis. There are no other warranties whatsoever, express or implied, concerning GPIO.

Purchaser's remedies are expressly limited to Printronix Auto ID Technology's obligations as stated above, and in no event shall Printronix Auto ID Technology be held liable for any incidental or consequential damages or loss of use, or other commercial loss, however occasioned.

THE WARRANTIES SET FORTH IN THIS ARTICLE AND THE OBLIGATIONS AND LIABILITIES THEREUNDER ARE IN LIEU OF, AND THE PURCHASER HEREBY WAIVES, ALL IMPLIED GUARANTEES AND WARRANTIES, INCLUDING WITHOUT LIMITATION, ANY WARRANTY OF MERCHANTABILITY OR FITNESS FOR A PARTICULAR PURPOSE. IN NO EVENT SHALL PRINTRONIX BE HELD LIABLE FOR ANY INCIDENTAL OR CONSEQUENTIAL DAMAGES OR LOSS OF USE, OR OTHER COMMERCIAL LOSS, HOWEVER OCCASIONED.

Notice of Copyright

This document contains proprietary information protected by copyright. No part of this document may be reproduced, copied, translated, or incorporated in any other material in any form or by any means, whether manual, graphic, electronic, mechanical, or otherwise, without the written consent of Printronix Auto ID Technology, Inc.

All non-Printronix registered and/or unregistered trademarks used throughout this manual are the sole property of their respective owners.

COPYRIGHT © 2016 PRINTRONIX AUTO ID TECHNOLOGY, INC. All rights reserved.

Table of Contents

| | |
|---|-----------|
| Product Warranty..... | 2 |
| Notice of Copyright..... | 2 |
| Table of Contents | 3 |
| 1 GPIO | 5 |
| Overview..... | 5 |
| Upgrading from T5000..... | 5 |
| Panel keys..... | 5 |
| Panel messages | 5 |
| Menu Overview  | 6 |
| GPIO Menu Descriptions..... | 7 |
| Connector Pinout..... | 11 |
| Signal Descriptions..... | 12 |
| Outputs..... | 12 |
| Inputs | 13 |
| Power and Grounds | 14 |
| Hardware Specifications..... | 14 |
| Pre-ProgrammedInputsforUsewithPrinterMenus | 14 |
| Pre-ProgrammedOutputsforUsewithPrinterMenus | 14 |
| External Power Outputs | 14 |
| Compatibility..... | 14 |
| Electrical..... | 14 |
| A Inputs And Outputs - Electrical..... | 17 |
| GPIO Opto-coupled Input Circuit..... | 17 |
| GPIO Opto-coupled Output Circuit..... | 17 |
| B Contact Information | 19 |

1 ***GPIO***

Overview

The Printronix General Purpose Input/Output (GPIO) module is an optional accessory for thermal printers. It enables the printers to interface with an external device such as a label applicator system.

Simple printer menus allow for programming three of the eleven pre-defined interface signals (seven outputs, four inputs) to select particular polarity or logic functions that can meet practically all typical print/apply requirements or be compatible with practically all the features available on other manufacturers' external I/O interfaces. This allows easy migration of Printronix thermal and line matrix printers to new or existing systems. Field interface is accomplished through an industry standard 50-pin D-type connector.

GPIO is available as a factory option or field installable kit that also includes a mating connector for field interface, installation instructions, and operation manual.

Although there are seven pre-defined outputs and four pre-defined inputs, the GPIO module actually contains a total of eight inputs, eight outputs (all inputs and outputs are optically-isolated), and four relays. By using Printronix GPIO Manager software, these can all be custom configured and be mapped in conjunction with Printronix proprietary functions such as ODV analyses, printer front panel keys, and communications ports to provide powerful functions, including multiple interfaces, previously not attainable with a single accessory module.

Upgrading from T5000

The GPIO board is a new design compared with the T5000, but the connections on the 50-pin connector are the same. The functionality is backwards compatible with T5000 regarding number of I/O's and the supported events and actions. However, to use an existing T5000 GPIO application on a later printer, some changes need to be made to the GPIO table:

- First, install the latest version of PrintNet Enterprise Suite (version 4.01L or later).
- Run the PrintNet Enterprise Suite application and open the GPIO Manager.
- Set the right printer model under File > GPIO Configuration > Printer Model.

Panel keys

Due to the differences in the front panel, events that relate to the panel keys will be highlighted in the table after you've changed the model number. This indicates that these entries need to be changed to use a proper key value. As newer printers have a different set of keys (e.g. the addition of the two soft keys) you need to redesign your solution to use the keys that are appropriate.

Panel messages

When displaying GPIO messages on the T5000, the existing message on the 2x16 character LCD display will be replaced. With newer models that have a larger display and use smaller fonts, GPIO messages will now be shown in a dedicated area on the online screen, still allowing displaying all other information like status, printer name etc. When the printer is offline, the GPIO messages will be shown in a pop-up box. To prevent annoying popups, it is recommended to design your GPIO solution in a way that messages are only shown when the printer is online.

Menu Overview

The GPIO menu is located under the System icon as shown in Figure 1 below. This submenu is only present if either the GPIO option is installed and/or a user defined table. The figure shows the available menus along with the defaults.

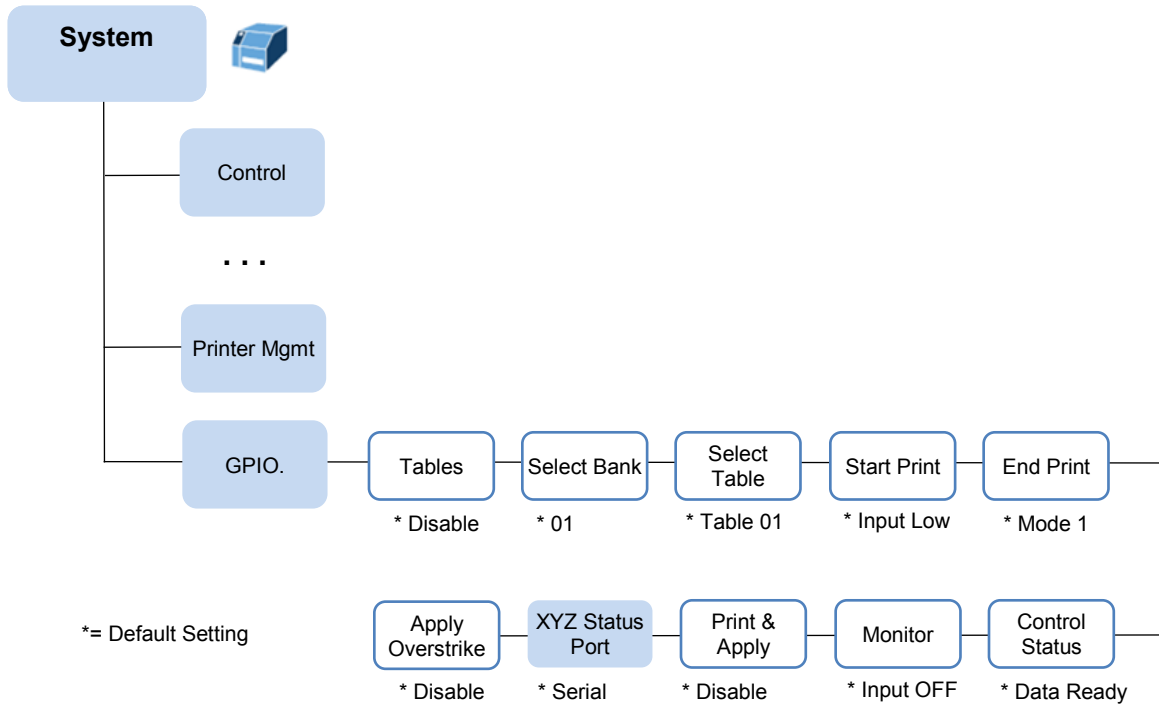

Figure 1 GPIO Menu Overview

IMPORTANT XYZ Status Port menu for reference only. This is a proprietary feature not available with the standard GPIO product.

GPIO Menu Descriptions

| System > GPIO > Tables | |
|---------------------------------------|--|
| Allows you to select a mapping table. | |
| Disable | The GPIO is not active. |
| Enable | The user-defined mapping table. |
| Internal | The standard internal mapping table. |
| User Defined | The user-defined mapping table. This option appears only if a user-defined table is downloaded to the printer |
| Factory Default | Disable |
| IMPORTANT | On Print & Apply machines, set GPIO Tables to Disable to avoid unexpected tamp motion during printer configuration. After all configurations are complete, set <i>Tables</i> to Enable. |

| System > GPIO > Select Bank | |
|--|--|
| Allows you to select a bank of tables. | |
| Minimum | 01 |
| Maximum | 08 (since the maximum number of tables is 64) |
| Range | The range is from 01 to X, where X is the total number of defined tables (see <i>Select Table</i> menu) divided by eight, rounded up to the next whole number (e.g., 15 tables = 2 banks). |
| Factory Default | 01 |
| IMPORTANT | This menu appears only if Tables is set to “Enable” or “User Defined”. |

| System > GPIO > Select Table | |
|---|---|
| Allows you to select a table. This menu appears only if <i>Tables</i> is set to "Enable" or "User Defined". | |
| Minimum | Table 01 |
| Maximum | Table 64 |
| Range | The range depends on the number of defined tables (maximum 64) and the GPIO Select Bank setting. See Table 1. |
| Factory Default | Table 01 |
| IMPORTANT | This menu appears only if <i>Tables</i> is set to "Enable" or "User Defined". |

Table 1 GPIO Sel. Table Range

| GPIO Select Bank Setting | GPIO Sel. Table Range |
|---------------------------------|------------------------------|
| 01 | 01 to 08 |
| 02 | 09 to 16 |
| 03 | 17 to 24 |
| 04 | 25 to 32 |
| 05 | 33 to 40 |
| 06 | 41 to 48 |
| 07 | 49 to 56 |
| 08 | 57 to 64 |

| System > GPIO > Start Print | |
|--|--|
| Start print logic. | |
| Input Low | Start print when input asserts low. |
| Input High | Start print when input asserts high. |
| Factory Default | Input Low |
| IMPORTANT | This menu appears only if <i>Tables</i> is set to "Internal". |

| System > GPIO > End Print | |
|--|---|
| End print logic. | |
| Mode 1 | Normally high. Low only when a label is being moved forward. |
| Mode 2 | Normally low; high only when a label is being moved forward. |
| Mode 3 | Normally high; low for 50 milliseconds when a label has been printed and positioned. Always high during continuous printing modes. |
| Mode 4 | Normally low; high for 50 milliseconds when a label has been printed and positioned. Always low during continuous printing modes. |
| Mode 5 | Normally high. When the label has been printed completely, a low going, 50 millisecond pulse is sent. (This mode shows the end of a label print cycle, even in batch mode where labels are continuously being printed.) |
| Mode 6 | Identical to Mode 5, except normally low with a high going 50 millisecond pulse. |
| Mode 7 | Normally high. At the beginning of a label being printed, the output is set low. When the label is completed, the signal goes high. If another label has started printing, the signal stays high for 50 milliseconds. (This mode shows start and end of a label print cycle, even in batch mode where labels are continuously printed.) |
| Mode 8 | Identical to Mode 7, except normally low with high going signal. |
| Factory Default | Mode 1 |
| IMPORTANT | This menu appears only if <i>Tables</i> is set to "Internal". |
| IMPORTANT | End print applies only to printed labels. Output remains in normal state for blank labels. |

| System > GPIO > Control Status | |
|---|---|
| Start print logic. This menu appears only for thermal printers, and only if <i>Tables</i> is set to "Internal". | |
| Data Ready | Low when sufficient data has been received to begin printing the next label. High whenever printing is stopped after the current label due to any condition causing the printer to pause or in the absence of a label format. |
| Offline | Low whenever the printer is offline. High whenever the printer is able to receive command streams and print labels. |
| Factory Default | Data Ready |
| IMPORTANT | This menu appears only if <i>Tables</i> is set to "Internal". |

| System > GPIO > Monitor | |
|---|---|
| Shows the status of the GPIO input opto-couplers on the control panel LCD. A '.' (dot) indicates that the corresponding opto-coupler is inactive. A ' ' (bar) indicates the opto-coupler is active. | |
| Input OFF | Start print when input asserts low. |
| Input ON | Start print when input asserts high. |
| Factory Default | Input OFF |
| IMPORTANT | This menu appears only if <i>Tables</i> is set to "Enable", "Internal", or "User Defined". |

| System > GPIO > Print&Apply | |
|--|------------------------------|
| Enables the use of print and apply hardware. | |
| Disable | Print & Apply mode disabled. |
| Enable | Print & Apply mode enabled. |
| Factory Default | Disable |

| System > GPIO > XYZ Status Port | |
|--|--|
| This menu is for reference only and not available with the standard product. | |
| Disable | Feature disabled. |
| E-NET Data Port | Data sent out the Ethernet designated data port. |
| Serial | Data sent out the serial port. |
| E-Net Stat Port | Data sent out the Ethernet designated status port. |
| USB | Data sent out the USB port. |
| IEEE 1284 | Data sent out the IEEE-1284 port. |
| Factory Default | Serial |

| System > GPIO > Apply Overstrike | |
|---|--|
| This menu is used when <i>Print&Apply</i> is set to "Enable". | |
| Disable | RFID or verifier overstrike labels are not applied to boxes. |
| Enable | RFID or verifier overstrike labels are applied to boxes like passing labels. |
| Factory Default | Disable |

Connector Pinout

The Printronix GPIO feature uses a 50-pin DIN connector to interface to Label Applicators, Programmable Logic Controllers, and the like.

Using the printer resident pre-programmed I/O mapping tables, a number of connector pins are each assigned a specific function as listed in the table below. See "Signal Descriptions" on page 14 for a complete description these functions.

| INPUT OPTO-COUPLER | | CONNECTOR PINS | |
|---------------------------|--------------------|-----------------------|--------------------|
| 1 | Reprint Last Label | 1 (anode) | 9 (cathode) |
| 2 | Start Print | 2 (anode) | 10 (cathode) |
| 3 | Feed | 3 (anode) | 11 (cathode) |
| 4 | Pause | 4 (anode) | 12 (cathode) |
| 5 to 8 | Not Used | 5 to 8 (anode) | 13 to 16 (cathode) |

| OUTPUT OPTO-COUPLER | | CONNECTOR PINS | |
|---------------------|------------------|----------------|--------------|
| 1 | Ribbon Low | 18 (collector) | 26 (emitter) |
| 2 | Ribbon Out | 19 (collector) | 27 (emitter) |
| 3 | Media Out | 20 (collector) | 28 (emitter) |
| 4 | Service Required | 21 (collector) | 29 (emitter) |
| 5 | End Print | 22 (collector) | 30 (emitter) |
| 6 | Control Status | 23 (collector) | 31 (emitter) |
| 7 | Not Used | 24 (collector) | 32 (emitter) |
| 8 | Power On | 25 (collector) | 33 (emitter) |

Signal Descriptions

Outputs

Ribbon Low

- Normally high, goes low when ribbon remaining is about 50 meters.
The menu *Media > Ribbon > Ribbon Low* can be set to “Disable” or “Enable.” If “Disable” is selected, the GPIO signal is disabled.
- Stays low when ribbon is out.

Ribbon Out

Normally high. Low during a Ribbon Out condition.

Media Out (Label Out)

Normally high. Low during a Label Out condition.

Error (Service Required)

Normally high. Goes low whenever the printer is stopped for a fault condition that requires the user to perform an action to start again. This can be head open, or any operation fault condition, etc.

End Print

Logic programmable via printer menu.

- **Mode 1.** The default. Normally high. Low only when a label is being moved forward.
- **Mode 2.** Normally low; high only when a label is being moved forward.
- **Mode 3.** Normally high; low for 50 milliseconds when a label has been printed and positioned. Always high during continuous printing modes.
- **Mode 4.** Normally low; high for 50 milliseconds when a label has been printed and positioned. Always low during continuous printing modes.
- **Mode 5.** Normally high. When the label has been printed completely, a low going, 50 millisecond pulse is sent. (This mode shows the end of a label print cycle, even in batch mode where labels are continuously being printed.)
- **Mode 6.** Identical to Mode 5, except normally low with a high going 50 millisecond pulse.

- **Mode 7.** Normally high. At the beginning of a label being printed, the output is set low. When the label is completed, the signal goes high. If another label has started printing, the high signal stays high for 50 milliseconds. (This mode shows start and end of a label print cycle, even in batch mode where labels are continuously printed.)
- **Mode 8.** Identical to Mode 7, except normally low with high going signal.

NOTE: End Print applies only to printed labels. Output remains in normal state for blank labels.

Data Ready/Off Line

Programmable via printer menu.

- **Ready Mode.** The default. Low when sufficient data has been received to begin printing the next label. High whenever printing is stopped after the current label due to any condition causing the printer to pause or in the absence of a label format.
- **Off Line Mode.** Low whenever the printer is offline. High whenever the printer is able to receive command streams and print labels.

Power On

Low when valid power is applied to printer, i.e., the main CPU is operating. During power off, this should be in a high impedance state so an external device can pull up to a voltage.

Inputs

Reprint

When low going edge is detected, the printer reprints the last label printed prior to receiving the signal. Only one label is reprinted. The signal must toggle high then low again to reprint another label.

StartPrint

Signal polarity selectable via printer menu.

- **Active Low.** The default. When low, the printer will print one label. If still low at the end of the label, another label will be printed without delay. If high, the printer will not print. If the signal goes high while the printer is printing a label, printing will continue until the label has completed. The printer will stop and obey any other settings for end of label control such as eject, feed a particular distance, etc.
- **Active High.** Identical to Mode 1 except opposite polarity. A high input will print one label, etc.

Feed

- If low, will feed a blank label (or labels) until a high input is detected. A high input stops the feeding of blank labels, and last blank label fed will stop at top-of-form.
- This signal has the lowest priority over other functions. If the printer is printing, ODV is voiding, or there are any error conditions, the signal is ignored.

NOTE: This signal also has lower priority than Start Print.

Pause

- When a signal toggles from high to low, it causes the printer to go into pause as if the PAUSE key were pressed.
- If a signal goes low during an operation, it will be treated the same way as if the PAUSE key were pressed, i.e., the label will finish if one was being printed, etc.
- This condition can only be reset by pressing the PAUSE key or by a similar command from a host if you have created one.

- The signal must toggle high then low again to achieve another valid pause input.

Power and Grounds

- +24 VDC
- 24 VDC Return (Ground)
- + 5 VDC
- 5 VDC Return (Ground)
- Frame Ground

Hardware Specifications

This section is a quick reference to the GPIO connections available when using the printer resident pre-programmed I/O mapping tables as well as the electrical specifications of the components used and the voltages available. See page 19 for a schematic diagram.

Pre-Programmed Inputs for Use with Printer Menus

Start Print (Polarity programmable via printer menu); input 2 Pause; input 4 Feed; input 3 Reprint; input 1 Not used; inputs 5, 6, 7, 8

Pre-Programmed Outputs for Use with Printer Menus

End Print (8 modes via printer menu); output 5 Data Ready/Online (programmable via printer menu); output 6 Ribbon Low; output 1 Ribbon Out; output 2 Error - Service Required; output 4 Media Out; output 3 Power On; output 8 Not used; output 7

External Power Outputs

+5VDC (.5 A fused)
+24VDC (.25 A fused) – not available if cutter installed Two DC ground pins

Compatibility

GPIO is compatible with all accessories except wireless communication options.

Electrical

Inputs (eight total)

- Opto-isolated, separate anode and cathode pins per input
- Input voltage range (steady state); 5-10 VDC
- Series resistor; 4700 ohm, .25W
- Resistor through hole mounted; changeable with common techniques

Outputs (eight total)

- Opto-isolated, NPN transistor, separate collector and emitter pins per output

- Open collector output, NPN transistor
- Current – 300 ma maximum
- 70 VDC collector to emitter voltage maximum.

Relays (four total)

- Each relay has three pins connected to the 50 pin connector: COM, NC and NO.
- Contacts are electrically isolated from the printer electronics.

WARNING For safety reasons voltage should be limited to 42 volts DC max.

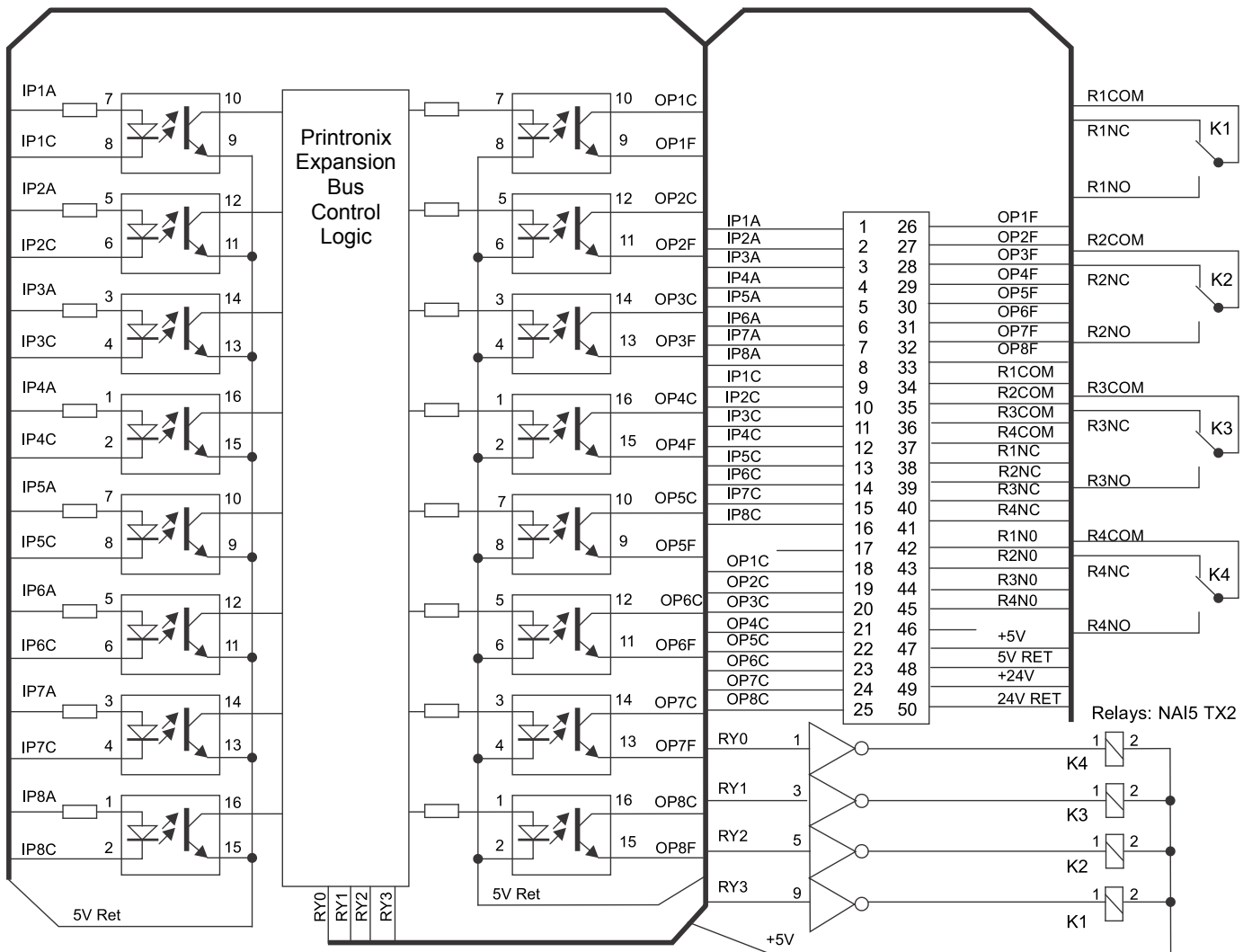

All anode protection resistors are 4.7K Ohms.

Figure 2 Basic GPIO Schematic Diagram

A *Inputs and Outputs - Electrical*

GPIO Opto-coupled Input Circuit

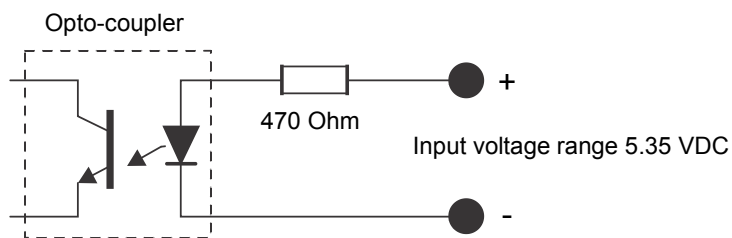

GPIO Opto-coupled Output Circuit

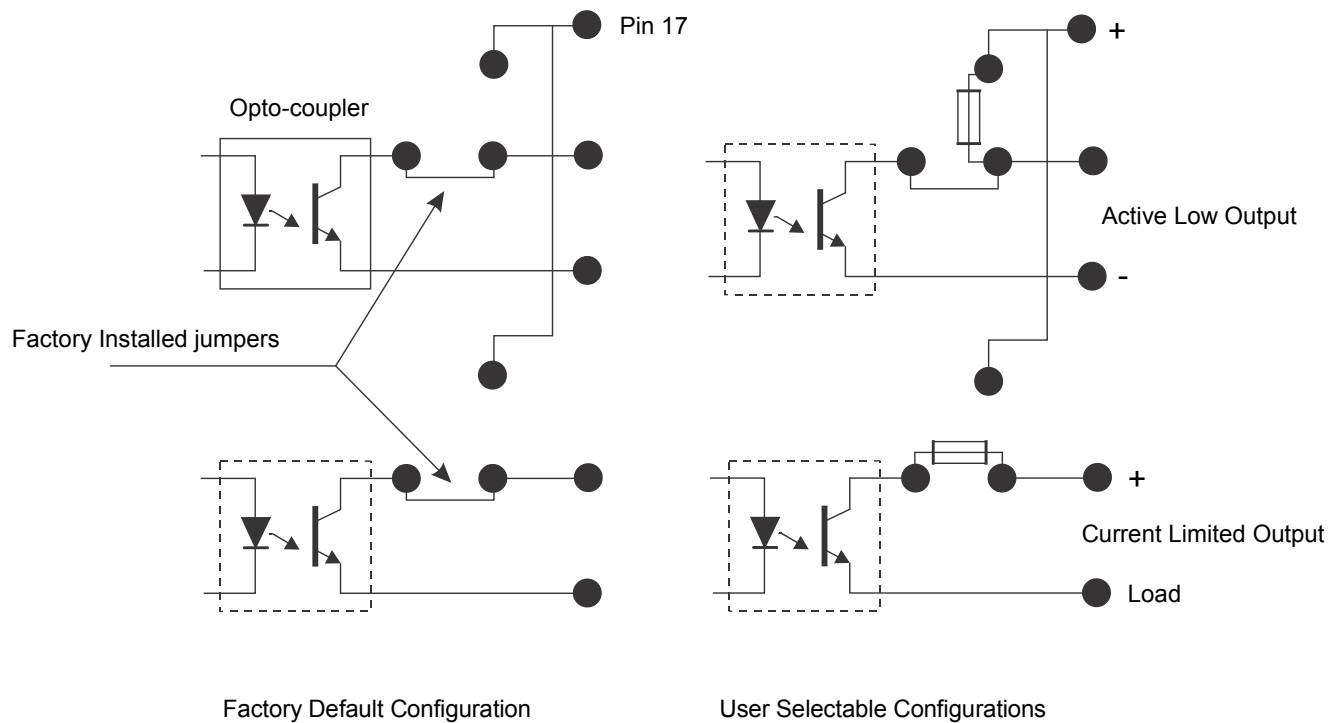

B *Contact Information*

Printronix Auto ID Customer Support Center

IMPORTANT Please have the following information available prior to calling the Printronix Customer Support Center:

- Model number
- Serial number (located on the back of the printer)
- Installed options (i.e., interface and host type if applicable to the problem)
- Configuration printout: Refer to the *Administrator's Manual*.
- Is the problem with a new install or an existing printer?
- Description of the problem (be specific)
- Good and bad pictures that clearly show the problem (faxing or emailing of these pictures may be required)

| | |
|--|--|
| Americas | (844) 307-7120 Service@PrintronixAutoID.com |
| Europe, Middle East, and Africa | +31 (0) 24 3030 340 EMEA_support@PrintronixAutoID.com |
| Asia Pacific | +886 3 990 6155 APAC_support@PrintronixAutoID.com |
| China | +86 755 2398 0479 CHINA_support@PrintronixAutoID.com |

Corporate Offices

Printronic Auto ID

3040 Saturn Street, Suite
200, Brea, CA 92821
U.S.A.

Phone: (844) 307-7120
Fax: (657) 258-0817

Printronic Auto ID, EMEA Head Office

Georg-Wimmer-Ring
8b D-85604 Zorneding, Germany

Phone: +49 (0) 8106 37979-000
Email: EMEA_Sales@PrintronicAutoID.com

Printronic Auto ID, Asia Pacific Head Office

Taiwan
9F, No. 95, Minquan Rd.
Xindian Dist., New Taipei City
231 Taiwan (R.O.C)

Phone: +886 3 990 6155
Fax: +886 3 990 6215

Printronic Auto ID, China Head Office

Shenzhen
New World Center 2510 room
No. 6009, Yitian road
Futian District, Shenzhen
518000
China

Phone: +86 755 2398 0479
Fax: +86 755 2398 0773

Visit the Printronic web site at www.PrintronicAutoID.com

258786-001 E