

Mobile Barcode Printers

# Alpha-2R Series

Direct Thermal

## Series Models

Alpha-2R



User Manual

# Copyright

**©2021 TSC Auto ID Technology Co., Ltd.**

The copyright in this manual, the software and firmware in the printer described are owned by TSC Auto ID Technology Co., Ltd. All rights reserved.

CG Triumvirate is a trademark of Agfa Corporation. CG Triumvirate Bold Condensed font is under license from the Monotype Corporation. Windows is a registered trademark of Microsoft Corporation.

All other trademarks are the property of their respective owners. Information in this document is subject to change without notice and does not represent a commitment on the part of TSC Auto ID Technology Co. No part of this manual may be reproduced or transmitted in any form or by any means, for any purpose other than the purchaser's personal use, without the expressed written permission of TSC Auto ID Technology Co.



# Table of Contents

<b>1</b>	<b>Introduction</b>	<b>1</b>
1.1	Specification	2
<b>2</b>	<b>Unpacking and Inspection</b>	<b>5</b>
<b>3</b>	<b>Getting to Know Your Printer</b>	<b>6</b>
3.1	Top/ Front View	6
3.2	Interior View	7
3.3	Rear/ Side View	8
3.4	Operator Control	9
<b>4</b>	<b>Setting up the Printer</b>	<b>11</b>
4.1	Installing the Battery	11
4.2	Charging the Battery	12
	<b>Charge the Battery</b>	12
	<b>Charge by Charger Station (Optional)</b>	14
4.3	Communication	16
4.4	Loading the Media	17
4.5	Installing the Belt Clip	18
4.6	Installing the IP54-rated environmental case with shoulder strap (Option)	19
4.7	Installing the Media Spacers (Option)	20
<b>5</b>	<b>Power-on Utilities</b>	<b>21</b>
5.1	Media Sensor Calibration	22
5.2	Self-test and Dump Mode	23
5.3	Printer Initialization	27
<b>6</b>	<b>TSC Console</b>	<b>28</b>
6.1	Launching TSC Console	28

6.2 Printer's Main Functions.....	30
6.3 Calibrating Media Sensor by TSC Console .....	31
6.4 Setting Bluetooth by TSC Console .....	32
6.5 Setting Wi-Fi by TSC Console.....	34
6.6 Initialize the Printer Wi-Fi Setting .....	37
<b>7 Troubleshooting.....</b>	<b>38</b>
<b>8 Maintenance .....</b>	<b>40</b>
<b>9 Agency Compliance and Approvals .....</b>	<b>42</b>
<b>Revision History .....</b>	<b>51</b>

# 1 Introduction

Thank you very much for purchasing TSC bar code printer.

Enjoy TSC's reputation for cost-efficient, high durability printers with the Alpha-2R economical printer. The Alpha-2R is a comfortable, light-weight printer capable of working with any mobile printing application where you need quick, simple receipts/labels on demand.

Our Alpha-2R is designed for a rough life, inside the IP54-rated environmental case to resist dust and water and with its rubber over-mold design prepared to take up to a five-foot fall and keep printing.

These small and light printers can be worn comfortably for a full shift, without interfering with the user's tasks. Use USB or optional Bluetooth, Wireless or Serial to connect to a mobile computer or even a smartphone and produce clear easy-to-read receipts hour after hour.

This document provides an easy reference for operating this printer. TSC printers include the Windows labeling software for creating your label template. For system integration, the TSPL/TSPL2 printer programming manual or SDKs can be found on TSC website at: <https://www.tscprinters.com>.

## 1.1 Specification

Model	Alpha-2R
Resolution	8 dots/mm (203 dpi)
Print Method	Direct Thermal
Max. Print Speed	Up to 102 mm (4")/second
Max. Print Width	48 mm (1.89")
Max. Print Length	2,286 mm (90")
Enclosure	Plastic
Physical Dimension	89.3 mm (W) x 134.5 mm (H) x 56.5 mm (D) 3.52" (W) x 5.3" (H) x 2.22" (D)
Weight (Including Battery)	350g (0.77lbs)
Drop Specification	1.5 m (5ft), with IP54 case can be 2 m (6.5ft)
IP Rating	IP42 (without case), IP54 (with case)
Max. Roll Capacity	50 mm (2") OD
Processor	32-bit RISC CPU
Memory	<ul style="list-style-type: none"> <li>▪ 128 MB Flash memory</li> <li>▪ 64 MB SDRAM</li> </ul>
Interface	<ul style="list-style-type: none"> <li>▪ USB 2.0</li> <li>▪ 802.11 a/b/g/n wireless (factory option)</li> <li>▪ Bluetooth 5.0 (factory option)</li> <li>▪ NFC (factory option)</li> <li>▪ RS-232 (user option)</li> </ul>
Power	Two-cell, 7.4V DC, 1620mAh Li-ion rechargeable battery

Model	Alpha-2R
<b>Operation Switch, Button</b>	<ul style="list-style-type: none"> <li>▪ 3 buttons (On/off, feed, and cover-open)</li> <li>▪ 2 color LED for printer status, 3 LEDs for battery status</li> </ul>
<b>Sensor</b>	<ul style="list-style-type: none"> <li>▪ Reflective sensor</li> <li>▪ Head open sensor</li> </ul>
<b>Internal Fonts</b>	<ul style="list-style-type: none"> <li>▪ 8 alpha-numeric bitmap fonts</li> <li>▪ One Monotype Imaging® CG Triumvirate Bold Condensed scalable font</li> </ul>
<b>Supported Barcode Formats</b>	<ul style="list-style-type: none"> <li>▪ 1D Barcodes Code 39, Code 93, Code128UCC, Code128 subsets A.B.C, Codabar, Interleave 2 of 5, EAN-8, EAN-13, EAN-128, UPC-A, UPC-E, EAN and UPC 2(5) digits add-on, MSI, PLESSEY, POSTNET, China POST, GS1 Data bar</li> <li>▪ 2D Barcodes PDF-417, Maxicode, DataMatrix, QR code, Aztec</li> </ul>
<b>Printer Language</b>	TSPL-EZ (EPL2, ZPL2), ESC-POS or CPCL emulation
<b>Media Type</b>	Receipt paper, bline receipt paper (Black mark in printing side) & selected label
<b>Media Width</b>	<ul style="list-style-type: none"> <li>▪ Max. 58 mm (2.28")</li> <li>* with adaptor: 50.8 mm (2") and 25.4 mm (1") (user option)</li> </ul>
<b>Media Thickness</b>	<ul style="list-style-type: none"> <li>▪ Receipt: 0.05 - 0.10 mm (2 - 4 mil)</li> <li>▪ Label: Up to 0.14 mm (5.5 mil)</li> </ul>
<b>Media Height</b>	<ul style="list-style-type: none"> <li>▪ Label: Min. 25.4 mm (1")</li> </ul>
<b>Environment Condition</b>	<ul style="list-style-type: none"> <li>▪ Operation: -20°C - 50°C (-4°F - 122°F), 10% - 90% non-condensing</li> <li>▪ Storage: -30°C - 70°C (-22°F - 158°F), 10% - 90% non-condensing</li> </ul>
<b>Factory Options</b>	<ul style="list-style-type: none"> <li>▪ 802.11 a/b/g/n wireless network</li> <li>▪ Bluetooth 5.0</li> <li>▪ Linerless kit</li> <li>▪ NFC</li> </ul>

Model	Alpha-2R
<b>User Options</b>	<ul style="list-style-type: none"><li>▪ Mini type USB 2.0</li><li>▪ USB to RS-232 converter cable</li><li>▪ Li-ion battery</li><li>▪ 1-slot battery charger</li><li>▪ 4-slot battery charger</li><li>▪ 12-24V DC vehicle power adaptor</li><li>▪ 12-60V DC vehicle power adaptor</li><li>▪ 12-60V DC vehicle open end power adaptor</li><li>▪ IP54-rated protective case with shoulder strap</li><li>▪ Media spacer kit</li></ul>



## 2 Unpacking and Inspection

This printer has been specially packaged to withstand damage during shipping. Please carefully inspect the packaging and printer upon receiving the bar code printer. Please retain the packaging materials in case you need to reship the printer.

Unpacking the printer, the following items are included in the carton.

- One printer unit
- One Li-ion battery
- One quick installation guide
- One auto-switching AC adapter
- One belt clip

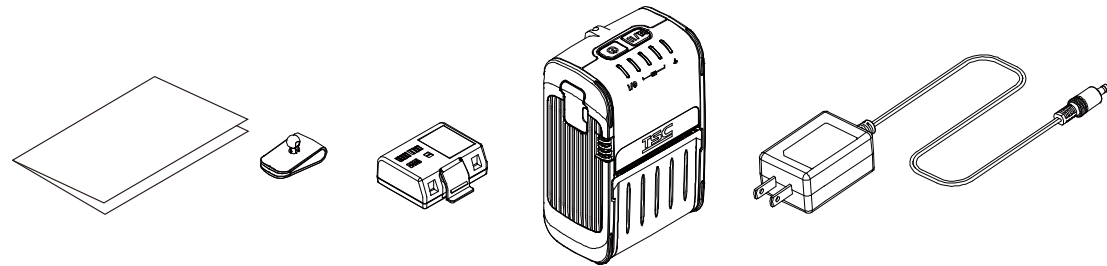

**Note: If anything is missing or damaged, please contact the customer service department of your reseller or distributor.**

# 3 Getting to Know Your Printer

## 3.1 Top/ Front View

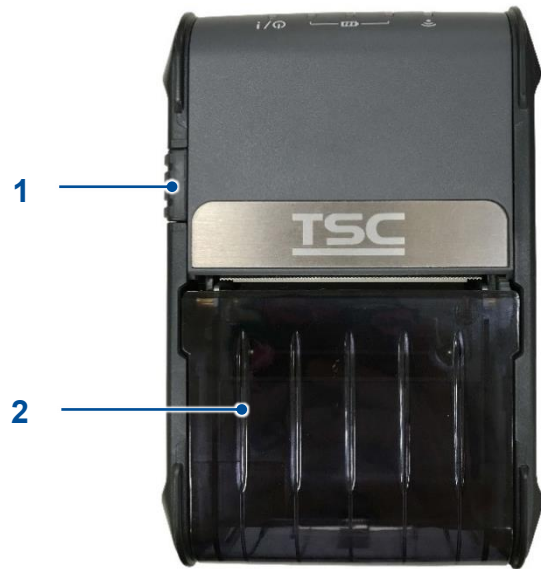

- 1. Media cover release button
- 2. Media cover
- 3. LED indicators
- 4. Feed/stop button
- 5. Power on/off button

## 3.2 Interior View

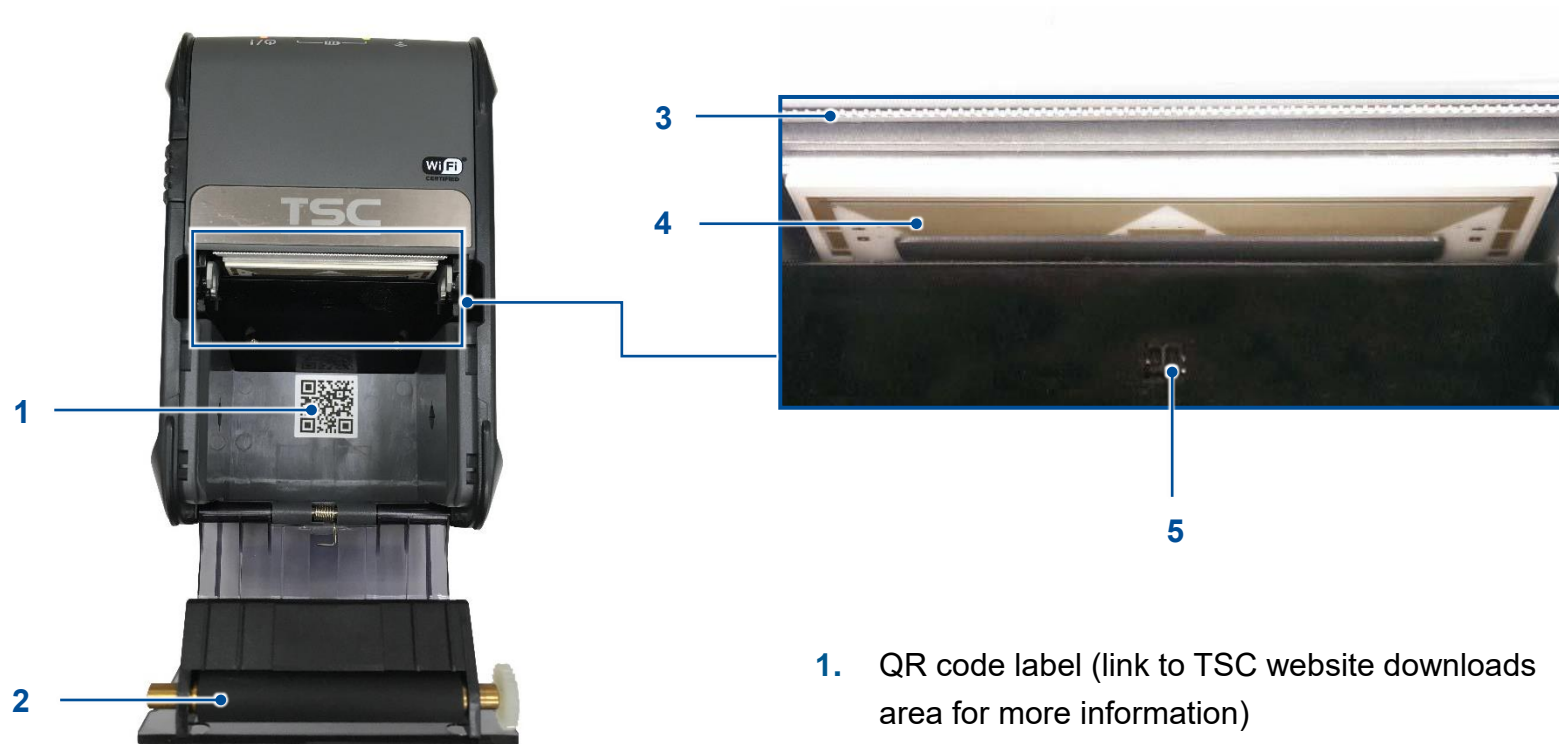

1. QR code label (link to TSC website downloads area for more information)
2. Platen roller
3. Tear edge
4. Print head
5. Black mark sensor

### 3.3 Rear/ Side View





## 3.4 Operator Control







1. Battery charge level LED indicators
2. Wireless status LED indicator
3. Feed/Pause button
4. Printer status LED indicator
5. Power on/off button

### ■ Keys

Keys	Function
	<ol style="list-style-type: none"><li>1. Press and hold for 2-3 seconds to turn on the printer.</li><li>2. Press and hold for 2-3 seconds to turn off the printer.</li></ol>
	<ol style="list-style-type: none"><li>1. Ready status: Feed one label</li><li>2. Printing status: Pause the print job</li></ol>

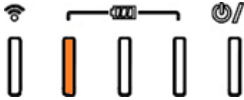
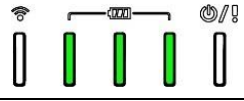
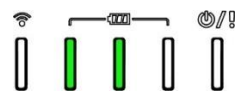
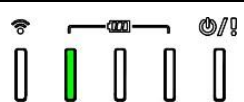
■ LED Indication

LED	Status		Indication
Printer status LED indicator 	Off		Printer is ready
	Green (blinking)		Printer is paused
	Green (blinking every two seconds)		Sleep mode/ entered the sleep mode after stop working over 2 minutes
	Red (solid)		Media cover is open
	Red (blinking)		Printer error
Battery status LED indicator 	Amber (solid)		Battery is charging
	Amber (blinking)		Battery needs to be charged
	Green (solid)		Fully charged
			2/3 charged level
			1/3 charged level
Wireless/Bluetooth status LED indicator 	Bluetooth	Blue (solid)	Bluetooth device is ready
		Blue (blinking)	Bluetooth device is communicating
	Wi-Fi	Green (solid)	Wireless device is ready
		Green (blinking)	Wireless device is communicating

# 4 Setting up the Printer

## 4.1 Installing the Battery

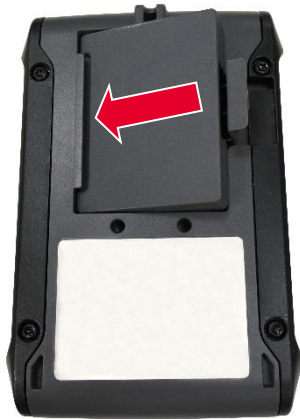

1. Insert battery to the left side of battery slot on the rear of the printer.



2. Push the battery down and pull the battery clasp to lock the battery.



### Battery safety warning:

- DO NOT throw the battery in fire. DO NOT short circuit the contacts.
- DO NOT disassemble the battery. DO NOT  throw the battery in municipal waste.
- The symbol of the crossed out wheeled bin (  ) indicates that the battery should not be placed in municipal waste.

## 4.2 Charging the Battery

### ■ Charge the Battery

Allow 1.5 to 2 hours to fully charge the battery before first use. The lifetime of the battery is 300 times for charge/discharge cycles.

1. Open the interface cover and plug the power cord into the power jack.



**Note:**

Please switch OFF printer power prior to plug in the power cord to printer power jack.

When the battery is charging, please do not remove the battery from the printer, otherwise, please re-plug the power cord into a power outlet.

2. Plug the power cord into a properly power outlet.





3. When the battery is charging, the color of battery status LED indicator is solid amber. The amber LED indicator will turn off after the battery is fully charged.

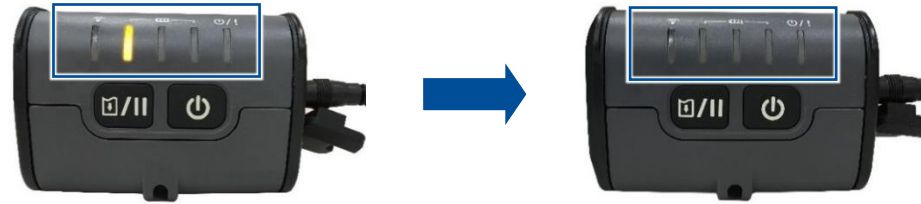

**Note:**

When checking the battery status, please connect the adapter and push power button, the LED indicator will turn to green then extinguished when the battery is fully charged.



## ■ Charge by Charger Station (Optional)

1. Plug the power cord to the power jack on the charger station.



2. Insert the printer battery along the slot to the charger station as pictured.

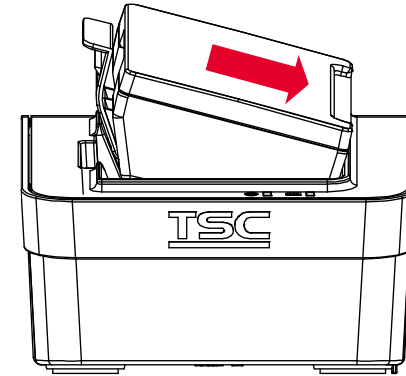

3. Push the battery down and locked by the latch as pictured, it can start charging.

**When charging, the status LED turns green blinking. After fully charged, the charger LED turns solid green. It will stop charging automatically after the battery is fully charged.**

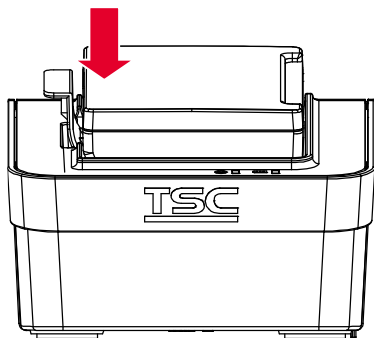

### Note:

**The four bay batteries charger station is also available for your reference.**

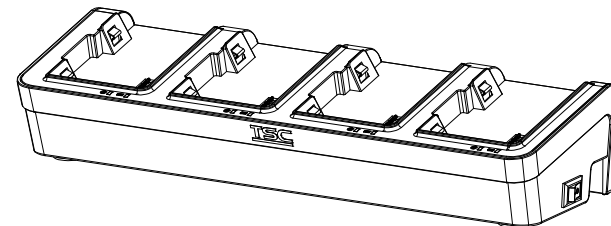

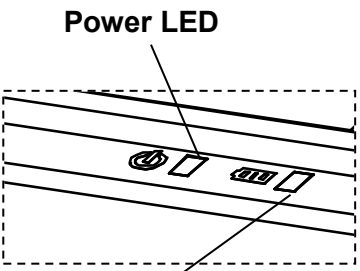
	LED	Color	Description
 <p data-bbox="295 236 454 263">Power LED</p> <p data-bbox="286 534 448 561">Status LED</p>	Power LED	Red / Solid	Charger powers up
	Status LED	Green / Solid	Battery is completely charged
		Green / Blinking	Battery is charging
		Red / Blinking	Battery charging error <b>Note:</b> - Battery temperature is over 50°C±5°C while charging, or charger current abnormal. - It is recommended to replace the battery.

## 4.3 Communication

### USB to USB Cable (Option)

Open the interface cover and connect the printer to the computer with USB cable.



### USB to RS-232 Cable (Option)

Open the interface cover and connect the printer to the computer with RS-232 cable.



### Connecting with Bluetooth (Option)

Turn on the printer and make sure the Bluetooth device opened.

**Note:** Refer to the chapter [Setting Bluetooth by TSC Console](#) to change the default name and PIN code.

Default	
Name	RF-BHS
PIN	0000

## 4.4 Loading the Media

1. Open the printer media cover by pressing the media cover release button.



2. Place the media roll at the correct side, and pull out enough paper over the tear edge. For narrow paper roll (1" or 2" width of media roll), see chapter Installing the Media Spacers (Option) to installing the media adapter first.

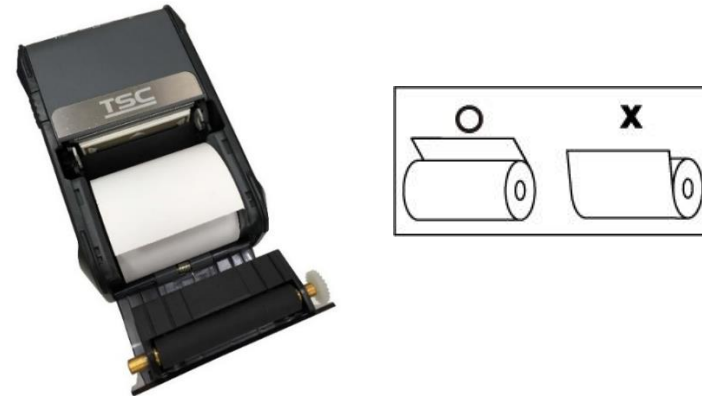

3. Press the media cover closed on both sides and make sure the media cover is properly closed.



4. Perform a media calibration for the media in use.  
For how to perform a media calibration, see chapter Media Sensor Calibration or chapter Calibrating Media Sensor by TSC Console to calibrate the media sensor.

## 4.5 Installing the Belt Clip

1. Remove the battery on the rear of the printer and lock the belt clip on the hole above the battery.



2. Press the ball on the belt clip to the hole as pictured.



3. After reinstalled the battery, the printer can be hung on the belt.



# 4.6 Installing the IP54-rated environmental case with shoulder strap (Option)

1. Open the zip along the arrow direction indicated on case cover.



2. Place the printer in the case.



**Note:** The printing side must face the outside cover as indicated.

3. Zip up the case cover. The outside cover should be opened and fixed while printing.



Outside cover



Outside cover fixed

## 4.7 Installing the Media Spacers (Option)

1. Open the printer top cover and install the media spacer in the media fixing hole as indicated.



2. The media spacers are installed in the media fixing hole on both sides.

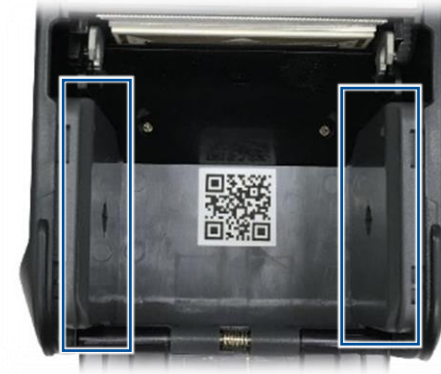

3. The media which installed in the spacers can prevent the poor print quality.

**Note: Here are 1" and 2" media spacers available for your reference.**



**2" media spacer**



**1" media spacer**



# 5 Power-on Utilities

There are three power-on utilities to set up and test printer hardware. These utilities are activated by pressing FEED button (📄/📄) then turning on the printer power simultaneously and release the button at different positions of LED indicator.

Please follow the steps below for different power-on utilities.

1. Turn off the printer power switch (🔌).
2. Hold on the FEED button (📄/📄) then turn on the power switch (🔌).
3. Release the button (📄/📄) when LED indicates with different positions for different functions.

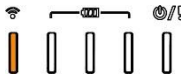
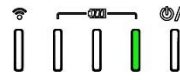
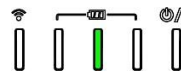
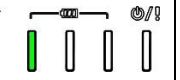
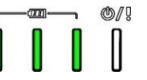
Power on utilities		The LED will be changed as following pattern:				
LED indicator						
Functions	(solid)	(5 blinks)	(5 blinks)	(5 blinks)	(Ready)	
1. Media sensor calibration		Release				
2. Self-test and enter dump mode			Release			
3. Printer initialization				Release		

## 5.1 Media Sensor Calibration

Please follow the steps below to calibrate the media sensor.

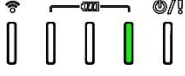
1. Turn off the power switch (🔌).
2. Please check if the media roll has installed correctly.
3. Hold on the FEED button (📄/📄) then turn on the power switch (🔌).
4. Release the FEED button (📄/📄) when the indicator becomes  and blinking five times (Any blink will do during the 5 blinks).
5. Printer will calibrate the media sensor sensitivity.

## 5.2 Self-test and Dump Mode

Please follow the steps below.

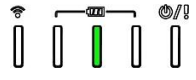
1. Please check if the media roll has installed correctly.
2. Turn off the power switch (🔌).
3. Hold on the FEED button (📄/🔊) then turn on the power switch (🔌).
4. Release the FEED button (📄/🔊) when the indicator becomes  and blinking (Any blink will do during the 5 blinks).
5. It calibrates the sensor and measures the media length and prints internal settings then enter the dump mode.

**Note: Turn off / on the power to resume printer for normal printing mode.**

■ Self-test

Printer will print the printer configuration after media sensor calibration. Self-test printout can be used to check if there is any dot damage on the heater element, printer configurations and available memory space.

**Self-test Printout**

```

-----
SYSTEM INFORMATION
-----
MODEL: XXXXXX
FIRMWARE: X.XX
CHECKSUM: XXXXXXXX
S/N: XXXXXXXXXXXX
TCF: NO
DATE: 1970/01/01
TIME: 00:04:18
NON-RESET: 110 m (TPH)
RESET: 110 m (TPH)
NON-RESET: 0 (CUT)
RESET: 0 (CUT)
-----
PRINTING SETTING
-----
SPEED: 3 IPS
DENSITY: 8.0
WIDTH: 2.84 INCH
HEIGHT: 4.00 INCH
BLINE: 0.00 INCH
INTENSION: 11
CODEPAGE: 850
COUNTRY: 001
SLEEP TIME: 30 Minutes
-----

```

- Model name
- F/W version
- Firmware checksum
- Printer S/N
- Configuration file
- System date
- System time
- Printed mileage (meter)
- Cutting counter
- Printing setting information
- Print speed (inch/sec)
- Print darkness
- Label size (inch)
- Black mark height (inch)
- Gap/black mark sensor intension
- Code page
- Country code
- Sleep time

## Self-test Printout

```
-----  
Z SETTING  
-----  
DARKNESS: 16.0  
SPEED: 4 IPS  
WIDTH: 4.00 INCH  
TILDE: 7EH (~)  
  
CARET: 5EH (^)  
DELIMITER: 2CH (,)  
POWER UP: NO MOTION  
HEAD CLOSE: NO MOTION  
-----
```

ZPL setting information

Print darkness

Print speed (inch/sec)

Label size

Control prefix

Format prefix

Delimiter prefix

Printer power up motion

Printer head close motion

Note: ZPL is emulating for Zebra® language.

```
-----  
BT SETTING  
-----  
MAC ADDR: DC1D307BD0D3  
NAME: 3R20-D0D3  
PIN CODE: 0000  
-----
```

Bluetooth setting information

```
-----  
BATTERY INFORMATION  
-----  
VOLTAGE: 8.2 V  
-----
```

Battery voltage

```
-----  
DRAM FILE (0 FILES)  
-----  
PHYSICAL XXXX KBYTES  
AVAILABLE XXXX KBYTES  
-----  
FLASH FILE (0 FILES)  
-----  
PHYSICAL XXXX KBYTES  
AVAILABLE XXXX KBYTES  
-----
```

Numbers of download files

Total & available memory space

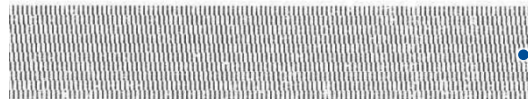

Printhead check pattern

## ■ Dump mode

Printer will enter dump mode after printing printer configuration. In the dump mode, all characters will be printed in 2 columns as following. The left side characters are received from your system and right side data are the corresponding hexadecimal value of the characters. It allows users or engineers to verify and debug the program.

SPEED 2.0	53 50 45 45 44 20 32 2E 30 0D
DENSITY 8	0A 44 45 4E 53 49 54 59 20 38
SET PEEL	0D 0A 53 45 54 20 50 45 45 4C
OFF DIRE	20 4F 46 46 0D 0A 44 49 52 45
CTION 0 0	43 54 49 4F 4E 20 30 0D 0A 47
AP 3.00 mm	41 50 20 33 2E 30 30 20 6D 6D
.0.00 mm	2C 30 2E 30 30 20 6D 6D 0D 0A
REFERENCE	52 45 46 45 52 45 4E 43 45 20
0.0 SET C	30 2C 30 0D 0A 53 45 54 20 43
UTTER OFF	55 54 54 45 52 20 4F 46 46 0D
SIZE 100.	0A 53 49 5A 45 20 31 30 30 2E
02 mm .65 0	30 32 20 6D 6D 2C 36 35 2E 30
4 mm CLS	34 20 6D 6D 0D 0A 43 4C 53 0D
BARCODE 1	0A 42 41 52 43 4F 44 45 20 31
44,149,"39	34 34 2C 31 34 39 2C 22 33 39
".120,1.0.	22 2C 31 32 30 2C 31 2C 30 2C
2.6,"57114	32 2C 36 2C 22 35 37 31 31 34
3BT" PRIN	33 38 54 22 0D 0A 50 52 49 4E
T 1.1 SPE	54 20 31 2C 31 0D 0A 53 50 45
ED 2.0 DE	45 44 20 32 2E 30 0D 0A 44 45
NSITY 8 S	4E 53 49 54 59 20 38 0D 0A 53
ET PEEL OF	45 54 20 50 45 45 4C 20 4F 46
F DIRECTI	46 0D 0A 44 49 52 45 43 54 49
ON 0 GAP	4F 4E 20 30 0D 0A 47 41 50 20
3.00 mm.0.	33 2E 30 30 20 6D 6D 2C 30 2E
00 mm REF	30 30 20 6D 6D 0D 0A 52 45 46
ERENCE 0.0	45 52 45 4E 43 45 20 30 2C 30
SET OUTT	0D 0A 53 45 54 20 43 55 54 54
ER OFF SI	45 52 20 4F 46 46 0D 0A 53 49
ZE 100.02	5A 45 20 31 30 30 2E 30 32 20
mm.65.04 m	8D 6D 2C 36 35 2E 30 34 20 6D
m CLS BA	6D 0D 0A 43 4C 53 0D 0A 42 41
RCODE 144.	52 43 4F 44 45 20 31 34 34 2C
149,"39" 1	31 34 39 2C 22 33 39 22 2C 31
20,1.0.2.6	32 30 2C 31 2C 30 2C 32 2C 36
"571143BT	2C 22 35 37 31 31 34 33 38 54
" PRINT 1	22 0D 0A 50 52 49 4E 54 20 31
.1	2C 31 0D 0A

ASCII Data

Hex decimal data related to left column of ASCII data

### Note:

1. Dump mode requires a paper width of 2 inches or more.
2. Turn off / on the power to resume printer for normal printing.

## 5.3 Printer Initialization

Printer initialization is used to clear DRAM and restore printer settings to defaults.

Printer initialization is activated by the following procedures.

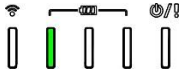
1. Turn off the power switch (🔌).
2. Hold on the FEED button (📄/📄) then turn on the power switch (🔌).
3. Release the FEED button (📄/📄) when the indicator becomes  and blinking. (Any blink will do during the 5 blinks).

# 6 TSC Console

Designed especially for the TSC printers, **TSC Console** enables users to deploy, manage, monitor, and troubleshoot both wired or wireless connections to one or a group of printers. **TSC Console** lowers IT costs and increases printer uptime with convenient out-of-the-box installation and a simplified Windows graphical user interface. It enhances robustness through integrated management capabilities and ensures that printers are available, reliable, and serviceable at all times.

## 6.1 Launching TSC Console

Follow the steps below to launch **TSC Console**:

1. Connect the USC cable with PC and printer. Turn on the printer.
2. Double click the **TSC Console** icon on the desktop of your computer to launch **TSC Console**. After launching **TSC Console**, the following screen will appear.

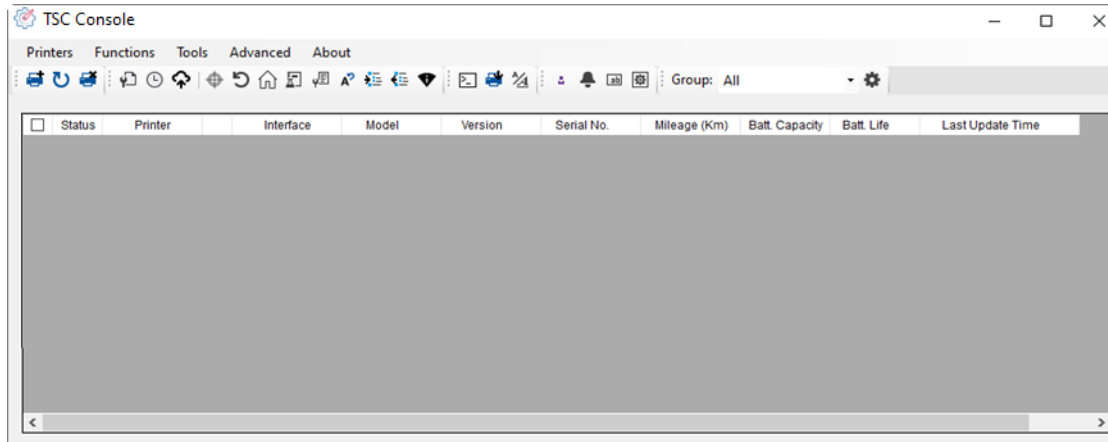

3. Select **Printers > Add Printers** to add the new printer to the **TSC Console** main page.

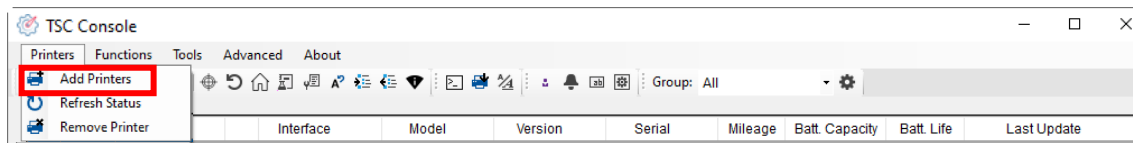



4. Select the **USB** and press the  button to find the printer, then select **OK** to add the printer.

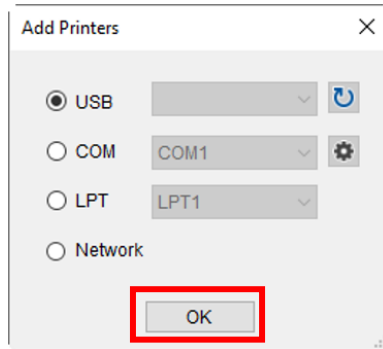

5. Select and start configuring the printer.

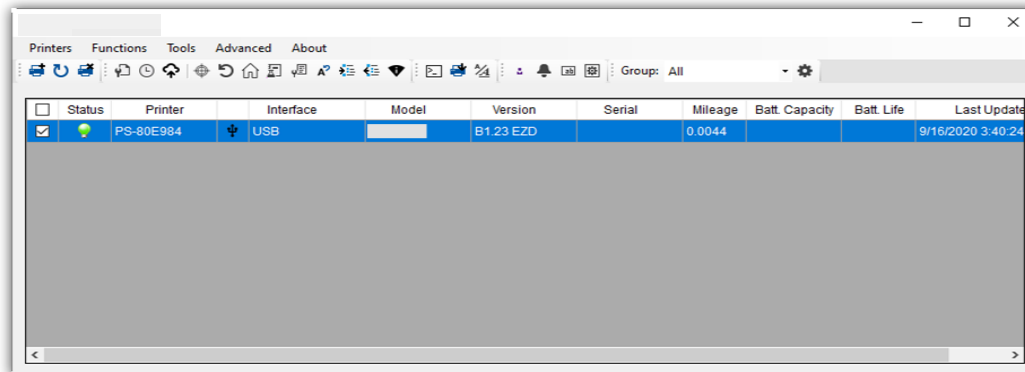

**NOTE:** You may refer to [TSC Console Manual](#) for further information.

## 6.2 Printer's Main Functions

The function buttons are located on the left side of the **Printer Configuration** page. You can use the function buttons to manage and configure the printer.

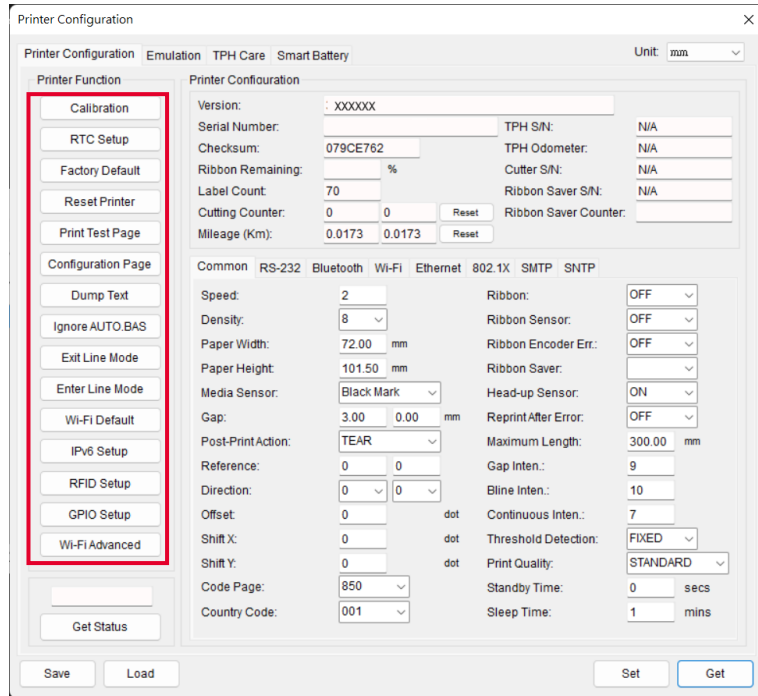

Item	Description
<b>Calibration</b>	Detects the media type and label size.
<b>RTC Setup</b>	Synchronizes the printer with the real time clock on the computer.
<b>Factory Default</b>	Restores the printer's settings to factory default values.
<b>Reset Printer</b>	Re-starts the printer.
<b>Print Test Page</b>	Prints test page based on the specified label size and sensor type.
<b>Configuration Page</b>	Prints the printer's configurations.
<b>Dump Text</b>	Activates Dump Mode.
<b>Ignore AUTO BAS</b>	Ignores the AUTO BAS file when the printer boots up.
<b>Exit Line Mode</b>	The printer will leave line mode and enter page mode.
<b>Enter Line Mode</b>	The printer will leave page mode and enter line mode.

**NOTE:** You may refer to [TSC Console Manual](#) for further information.

## 6.3 Calibrating Media Sensor by TSC Console

1. Make sure the media is already installed and media cover is closed. Connect the USB cable with printer and PC. Turn on the printer.
2. Launch the **TSC Console** and add the new printer to the **TSC Console** main page. (Refer to Launching TSC Console)
3. Select the printer and enter the **Printer Configuration** window. (Functions > Printer Configuration)



4. Click the **Calibration** button to bring up the setup window. Select the media type and click the **Calibrate** button in **Auto Calibration** to perform the media sensor calibration.

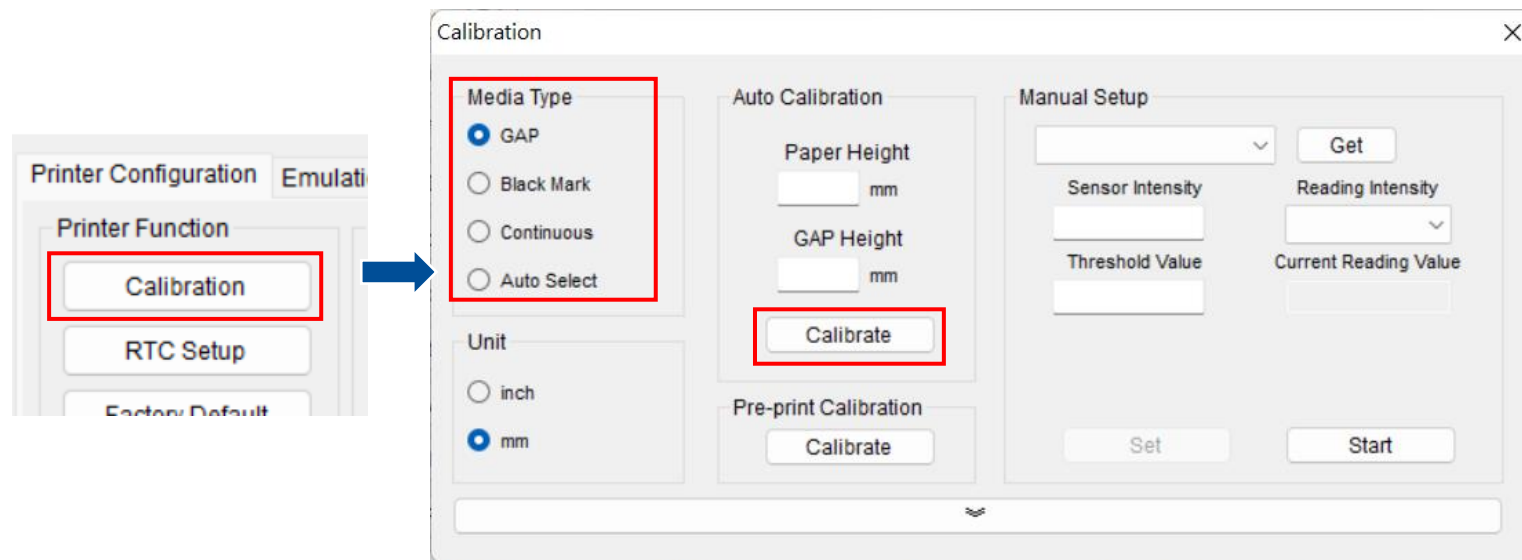

## 6.4 Setting Bluetooth by TSC Console

1. Use **USB** or **COM Port** to add the printer to the TSC Console main page. (Refer to Launching TSC Console)  
Select the printer and enter the **Printer Configuration** window. (Functions > Printer Configuration)

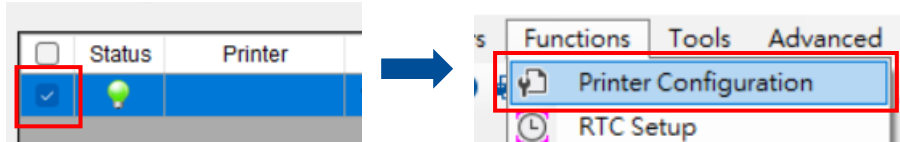

2. Select the **Bluetooth** tab. Press the **Get** button to read the Bluetooth settings currently in the printer.

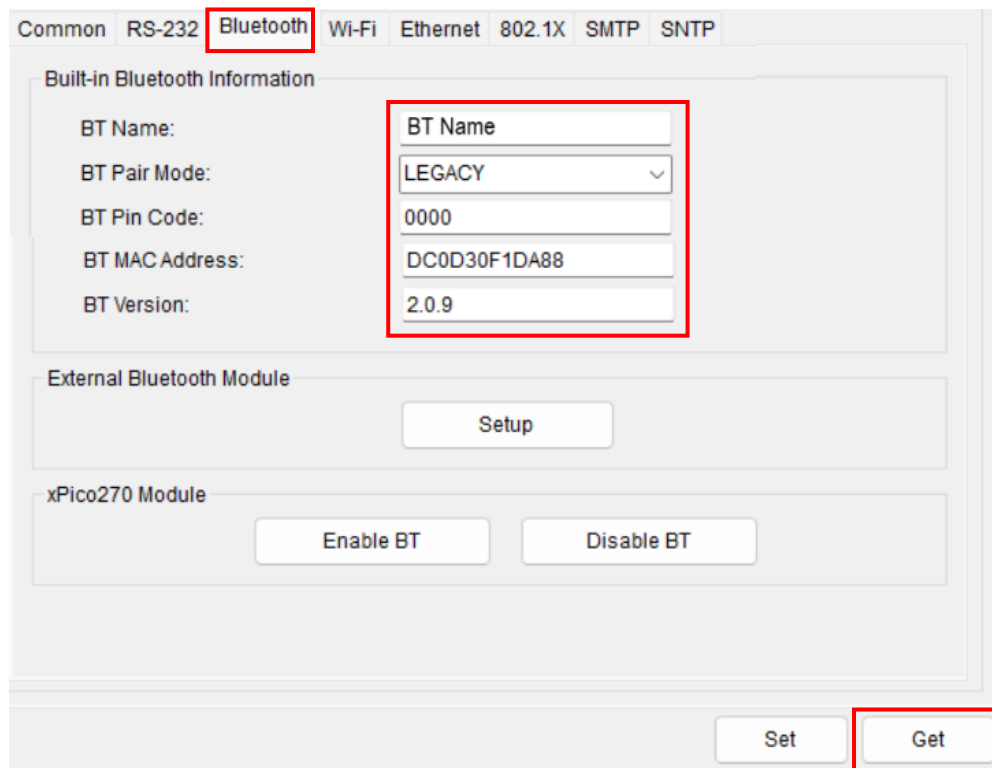

3. Enter the new BT Local Name or BT PIN Code in the editor. (The editor area will turn yellow when the value is changed.)
4. Press the **Set** button to set the new BT name or BT PIN code into the printer.  
Press the **Get** button to get the settings to confirm that the new Bluetooth module settings have been correctly set into the printer.

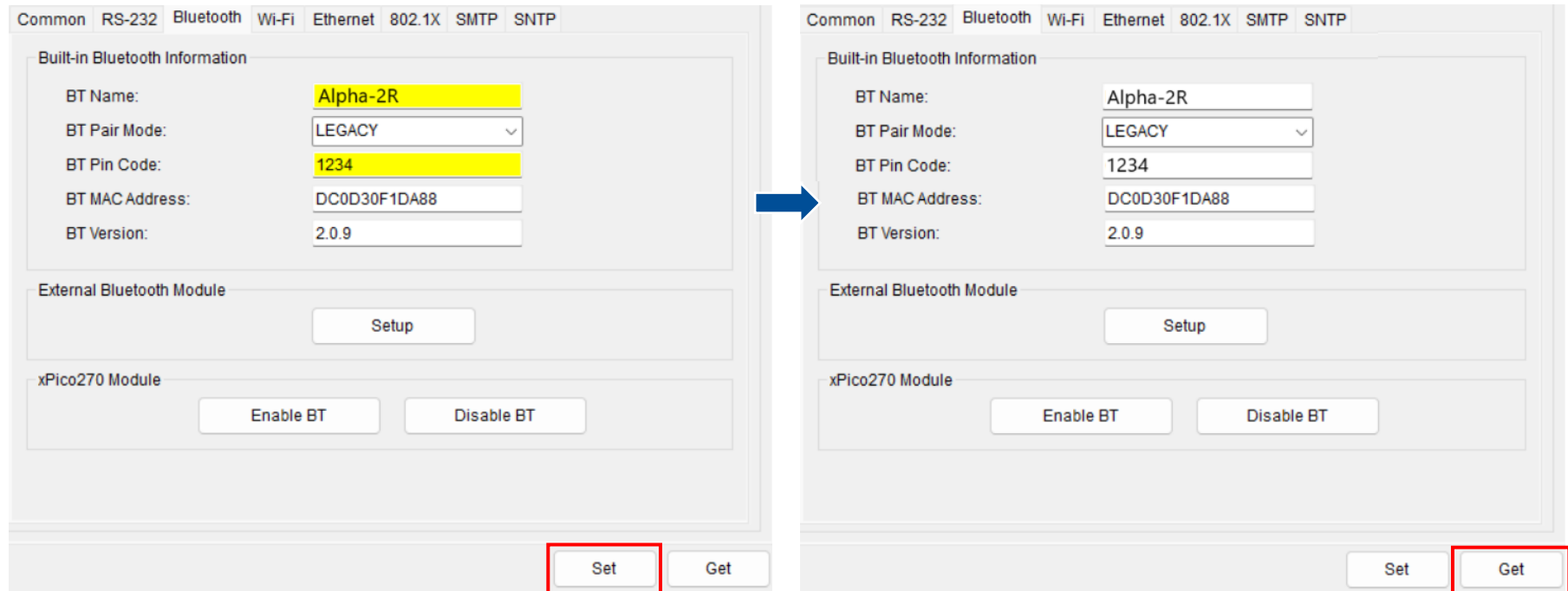

## 6.5 Setting Wi-Fi by TSC Console

1. Use **USB** or **COM Port** to add the printer to the TSC Console main page. (Refer to Launching TSC Console)  
Select the printer and enter the **Printer Configuration** window. (Functions > Printer Configuration)

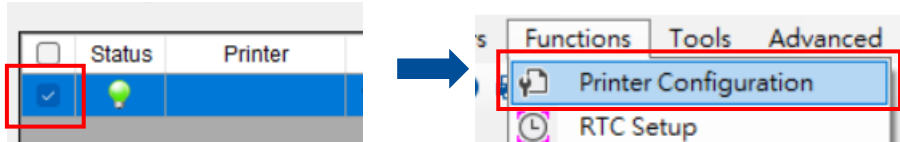

2. Click **Wi-Fi** to the wi-fi setting page. Click **Get** to receive printer's Wi-Fi information. Then refer to next page to set the Wi-Fi module.

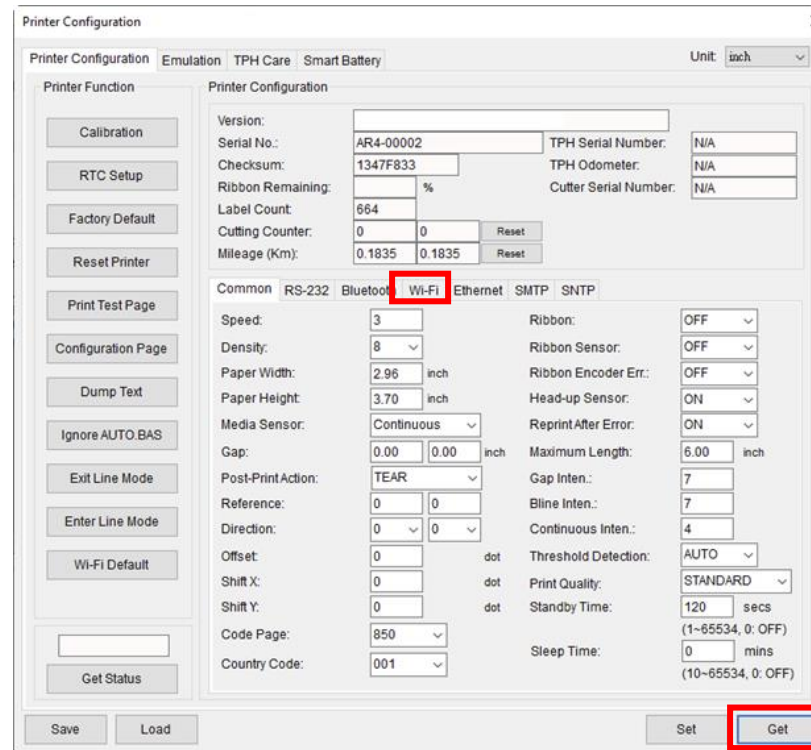
The image shows a screenshot of the 'Printer Configuration' window. The 'Wi-Fi' tab is selected and highlighted with a red box. The window contains various settings for the printer, including version, serial numbers, ribbon status, and network settings. The 'Get' button at the bottom right is also highlighted with a red box.

Common	RS-232	Bluetooth	Wi-Fi	Ethernet	SMTP	SNTP
Speed:	3				Ribbon:	OFF
Density:	8				Ribbon Sensor:	OFF
Paper Width:	2.96	inch			Ribbon Encoder Err.:	OFF
Paper Height:	3.70	inch			Head-up Sensor:	ON
Media Sensor:	Continuous				Reprint After Error:	ON
Gap:	0.00	0.00	inch		Maximum Length:	6.00
Post-Print Action:	TEAR				Gap Inten.:	7
Reference:	0	0			Blint Inten.:	7
Direction:	0	0			Continuous Inten.:	4
Offset:	0		dot		Threshold Detection:	AUTO
Shift X:	0		dot		Print Quality:	STANDARD
Shift Y:	0		dot		Standby Time:	120
Code Page:	850					(1-65534, 0: OFF)
Country Code:	001				Sleep Time:	0
						(10-65534, 0: OFF)

### For WPA-Personal

- I. Fill-in the **SSID**.
- II. Select the Encryption option to **WPA-Personal**.
- III. Fill-in the Key.
- IV. Select **DHCP** to **ON**. (For **OFF** option, please fill-in the IP Address, Subnet Mask and Gateway)
- V. After setting, click the **Set** button.

#### Note:

Before setting, the entered field will be shown in yellow for reminding. On DHCP, user can change the printer name by another model name in "Printer Name" field.

User also can change the raw port in "Raw Port" field.

Common RS-232 Bluetooth Wi-Fi Ethernet SMTP SNTP

Built-in Wi-Fi Module

SSID: SSID\_1

WLAN Encryption: WPA-Personal

Key: \*\*\*\*\*

DHCP: ON

IP Address: 1

Subnet Mask: 0.0.0.0

Gateway:

Primary DNS IP:

Secondary DNS IP:

Raw Port: 9100

Printer Name: PS-FF153C

MAC Address: 00:1B:82:FF:15:3C

EAP Type:

Username:

Password:

File Name Browse

CA Certificate: ...

Client Certificate: ...

Private Key: ...

EAP-FAST PAC: ...

Wi-Fi Version: 3.7.1.0R6

RSSI: 0

Set Get

### For WPA-Enterprise

- I. Fill-in the **SSID**.
- II. Select the Encryption option to **WPA2-Enterprise**.
- III. Select DHCP to **ON** (For **OFF** option, please fill-in the IP Address, Subnet Mask and Gateway)
- IV. Select the **EAP Type** option. (For **EAP-TLS** option, please upload the CA and Key for mutual authentication, integrity-protected cipher suite negotiation, and key exchange between two endpoints.)
- V. After setting, click the **Set** button.

#### Note:

Before setting, the entered field will be shown in yellow for reminding. On DHCP, user can change the printer name by another model name in "Printer Name" field.

User also can change the raw port in "Raw Port" field.

Common RS-232 Bluetooth Wi-Fi Ethernet SMTP SNTP

Built-in Wi-Fi Module

SSID: SSID\_2

WLAN Encryption: WPA-Enterprise

Key: \*\*\*\*\*

DHCP: ON

IP Address: 1

Subnet Mask: 0.0.0.0

Gateway:

Primary DNS IP:

Secondary DNS IP:

Raw Port: 9100

Printer Name: PS-FF153C

MAC Address: 00:1B:82:FF:15:3C

EAP Type: 2

Username:

Password:

File Name Browse

CA Certificate: ...

Client Certificate: ...

Private Key: ...

EAP-FAST PAC: ...

Wi-Fi Version: 3.7.1.0R6

RSSI: 0

Set Get

3. After clicking **Set** button, it'll pop-up the window tip as below shown.

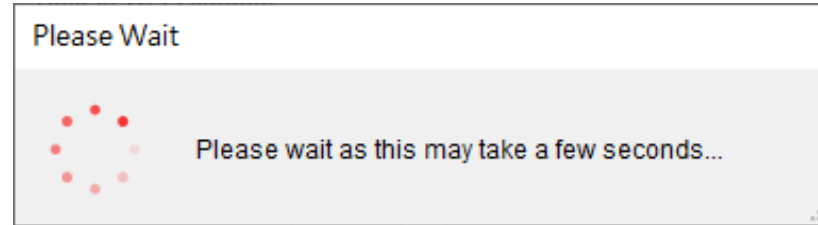

4. IP address will be shown in the "IP address" field.
5. Remove the cable between the computer and the printer.
6. Go to main page, click **Add Printer** to add the printer via **Network**.

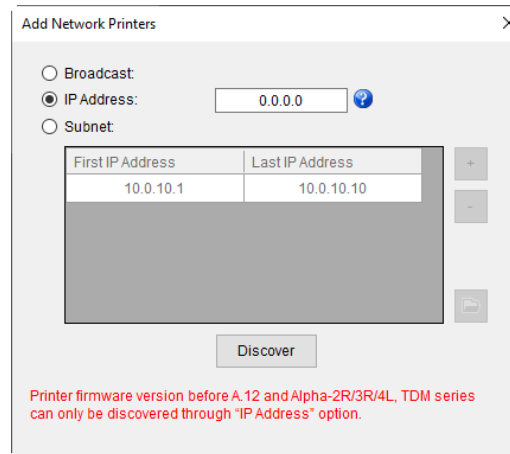

7. Select the printer and enter the setting page by double clicking the printer.
8. Click the **Print Test Page** button to print the test page via Wi-Fi interface.



## 6.6 Initialize the Printer Wi-Fi Setting

1. Return to the main page of TSC Console. Click **Functions** to expand the page.

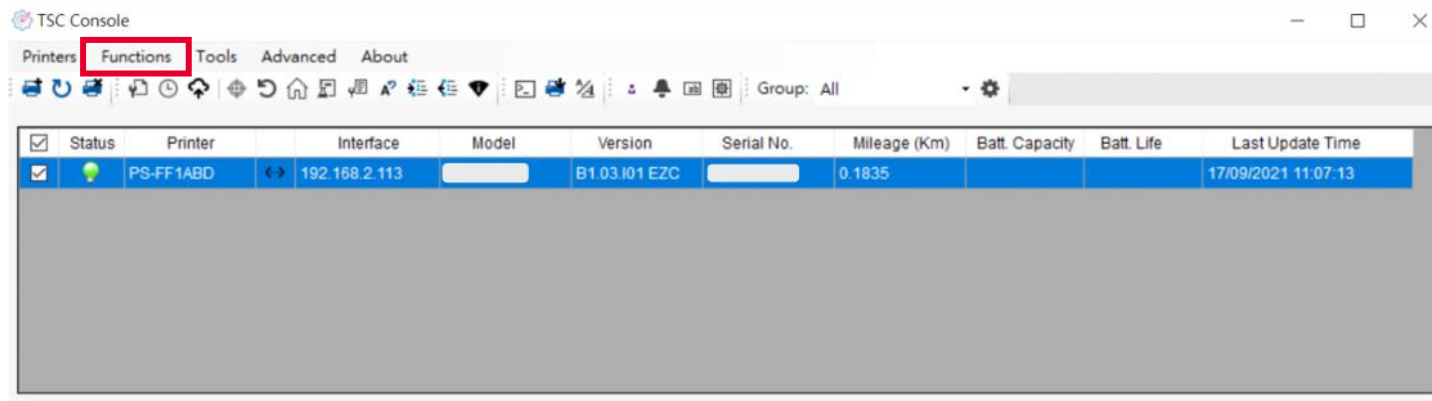

2. Click **Wi-Fi Default** to initialize the printer Wi-Fi module setting to factory default setting.

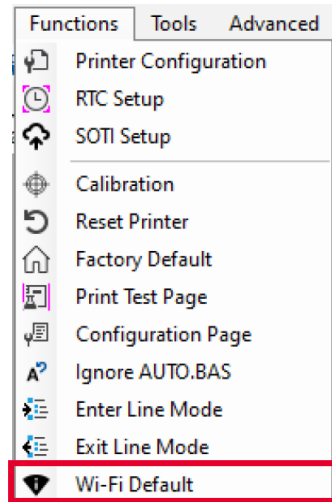

# 7 Troubleshooting

Problem	Possible Cause	Recovery Procedure
<b>Power indicator does not illuminate</b>	<ul style="list-style-type: none"> <li>• The battery is not properly installed.</li> <li>• The battery metal contacts pins are with dirt.</li> <li>• The battery is dead.</li> </ul>	<ul style="list-style-type: none"> <li>• Clean the battery metal contacts.</li> <li>• Reinstall the battery.</li> <li>• Switch the printer on.</li> <li>• Charge the battery.</li> </ul>
The printer status from TSC Console shows <b>“Head Open”</b> .	<ul style="list-style-type: none"> <li>• The printer carriage is open.</li> </ul>	<ul style="list-style-type: none"> <li>• Please close the print carriage.</li> </ul>
The printer status from TSC Console I shows <b>“Out of Paper”</b> .	<ul style="list-style-type: none"> <li>• Running out of media roll.</li> <li>• The media is installed incorrectly.</li> <li>• Media sensor is not calibrated.</li> </ul>	<ul style="list-style-type: none"> <li>• Supply a new media roll.</li> <li>• Refer to the steps on chapter <a href="#">Loading the Media</a> to reinstall the media roll.</li> <li>• Refer to the chapter <a href="#">Media Sensor Calibration</a> or chapter <a href="#">Calibrating Media Sensor by TSC Console</a> to calibrate the media sensor.</li> </ul>
The printer status from TSC Console shows <b>“Paper Jam”</b> .	<ul style="list-style-type: none"> <li>• Black mark sensor is not set properly.</li> <li>• Make sure media size is set properly.</li> <li>• Media may be stuck inside the printer mechanism.</li> </ul>	<ul style="list-style-type: none"> <li>• Calibrate the black mark sensor.</li> <li>• Set media size correctly.</li> <li>• Clean the printer mechanism.</li> </ul>
<b>Memory full (FLASH / DRAM)</b>	<ul style="list-style-type: none"> <li>• The space of FLASH/DRAM is full.</li> </ul>	<ul style="list-style-type: none"> <li>• Delete unused files in the FLASH/DRAM.</li> <li>• Run printer self-test and check the available memory space for DRAM or FLASH.</li> <li>• Check the available memory space for DRAM or FLASH via TSC Console.</li> </ul>

Problem	Possible Cause	Recovery Procedure
<b>Poor Print Quality</b>	<ul style="list-style-type: none"> <li>• Media cover is not fully latched.</li> <li>• Media is loaded incorrectly.</li> <li>• Dust or adhesive accumulation on the printhead.</li> <li>• Print density is not set properly.</li> <li>• Print head element is damaged.</li> </ul>	<ul style="list-style-type: none"> <li>• Make sure the right/ left side of media cover is fully latched.</li> <li>• Clean the printhead.</li> <li>• Clean the platen roller.</li> <li>• Adjust the print density and print speed.</li> <li>• Run printer self-test and check the printhead test pattern if there is dot missing in the pattern.</li> <li>• Change proper media roll.</li> </ul>
<b>Missing printing on the left or right side of label</b>	<ul style="list-style-type: none"> <li>• Wrong label size setup.</li> </ul>	<ul style="list-style-type: none"> <li>• Set the correct label size.</li> </ul>
<b>Gray line on the blank label</b>	<ul style="list-style-type: none"> <li>• The print head is dirty.</li> <li>• The platen roller is dirty.</li> </ul>	<ul style="list-style-type: none"> <li>• Clean the print head.</li> <li>• Clean the platen roller.</li> </ul>
<b>Irregular printing</b>	<ul style="list-style-type: none"> <li>• The printer is in Hex Dump mode.</li> <li>• The RS-232 setting is incorrect.</li> </ul>	<ul style="list-style-type: none"> <li>• Turn off and on the printer to skip the dump mode.</li> <li>• Re-set the Rs-232 setting.</li> </ul>

# 8 Maintenance

This session presents the clean tools and methods to maintain the printer.

## ■ For Cleaning

Depending on the media used, the printer may accumulate residues (media dust, adhesives, etc.) as a by-product of normal printing. To maintain the best printing quality, you should remove these residues by cleaning the printer periodically. Regularly clean the print head and supply sensors once change a new media to keep the printer at the optimized performance and extend printer life.

## ■ For Disinfecting

Sanitize your printer to protect yourself and others and can help prevent the spread of viruses.

## ■ Important

- Set the printer power switch to O (Off) prior to performing any cleaning or disinfecting tasks. Leave the power cord connected to keep the printer grounded and to reduce the risk of electrostatic damage.
- Do not wear rings or other metallic objects while cleaning any interior area of the printer.
- Use only the cleaning agents recommended in this document. Use of other agents may damage the printer and void its warranty.
- Do not spray or drip liquid cleaning solutions directly into the printer. Apply the solution on a clean lint-free cloth and then apply the dampened cloth to the printer.
- Do not use canned air in the interior of the printer as it can blow dust and debris onto sensors and other critical components.
- Only use a vacuum cleaner with a nozzle and hose that are conductive and grounded to drain off static build up.
- All reference in these procedures for use of isopropyl alcohol requires that a 99% or greater isopropyl alcohol content be used to reduce the risk of moisture corrosion to the printhead.
- Do not touch printhead by hand. If you touch it carelessly, please use 99% Isopropyl alcohol to clean it.
- Always taking personal precaution when using any cleaning agent.

## Cleaning Tools

- Cotton swab
- Lint-free cloth
- Brush with soft non-metallic bristles
- Vacuum cleaner
- 75% Ethanol (for disinfecting)
- 99% Isopropyl alcohol (for printhead and platen roller cleaning)
- Genuine printhead cleaning pen
- Mild detergent (without chlorine)

## Cleaning Process:

Printer Part	Method	Interval
<b>Print Head</b>	<ol style="list-style-type: none"> <li>I. Always turn off the printer before cleaning the printhead.</li> <li>II. Allow the printhead to cool for at least one minute.</li> <li>III. Use a cotton swab and 99% Isopropyl Alcohol or genuine print head cleaning pen to clean the print head surface.</li> </ol>	Clean the print head when changing a new label roll.
<b>Platen Roller</b>	<ol style="list-style-type: none"> <li>I. Turn off the printer.</li> <li>II. Rotate the platen roller and wipe it thoroughly with the lint-free 99% Isopropyl Alcohol.</li> </ol>	Clean the platen roller when changing a new label roll
<b>Tear Bar</b>	Use the lint-free cloth with 99% Isopropyl Alcohol to wipe it.	As needed
<b>Sensor</b>	Use brush with soft non-metallic bristles or a vacuum cleaner, to remove paper dust. Clean upper and lower media sensors to ensure reliable Top of Form and Paper Out sensing.	Monthly
<b>Exterior</b>	Clean the exterior surfaces with a clean, lint-free cloth (water-dampened cloth). If necessary, use a mild detergent or desktop cleaning solution then use the 75% Ethanol to wipe it.	As needed
<b>Interior</b>	Clean the interior of the printer by removing any dirt and lint with a vacuum cleaner, as described above, or use a brush with soft non-metallic bristles then use the 75% Ethanol to wipe it.	As needed

# 9 Agency Compliance and Approvals



2014/30/EU(EMC), 2014/35/EU(LVD), 2011/65/EU(RoHS 2.0)  
EN 55032 Class B  
EN 55024  
EN61000-3-2:2014  
EN61000-3-3:2013  
EN 60950-1

## FCC part 15B, Class B

This equipment has been tested and found to comply with the limits for a Class B digital device, pursuant to part 15 of the FCC Rules. These limits are designed to provide reasonable protection against harmful interference in a residential installation. This equipment generates, uses and can radiate radio frequency energy and, if not installed and used in accordance with the instructions, may cause harmful interference to radio communications. However, there is no guarantee that interference will not occur in a particular installation. If this equipment does cause harmful interference to radio or television reception, which can be determined by turning the equipment off and on, the user is encouraged to try to correct the interference by one or more of the following measures:



- Reorient or relocate the receiving antenna.
- Increase the separation between the equipment and receiver.
- Connect the equipment into an outlet on a circuit different from that to which the receiver is connected.
- Consult the dealer or an experienced radio/ TV technician for help.

This device complies with Part 15 of the FCC Rules. Operation is subject to the following two conditions: (1) This device may cause harmful interference, and (2) this device must accept any interference received, including interference that may cause undesired operation.

## This Class B digital apparatus complies with Canadian ICES-003

Cet appareil numérique de la classe B est conforme à la norme NMB-003 du Canada.



AS/NZS CISPR 22 Class B  
AS/NZS CISPR 32 Class B



**EN 60950-1**



**NOM-019-SCFI-1998**



**10 C.F.R. Section 430.23(aa) (Appendix Y to Subpart B of part 430)**



**Energy Star for Imaging Equipment 2.0**



**TP TC 004/2011  
TP TC 020/2011**



**LP0002**

Important safety instructions:

1. Read all of these instructions and keep them for later use.
2. Follow all warnings and instructions on the product.
3. Disconnect the power plug from the AC outlet before cleaning or if fault happened.  
Do not use liquid or aerosol cleaners. Using a damp cloth is suitable for cleaning.
4. The mains socket shall be installed near the equipment and easily accessible.
5. The unit must be protected against moisture.
6. Ensure the stability when installing the device, Tipping or dropping could cause damage.
7. Make sure to follow the correct power rating and power type indicated on marking label provided by manufacture.

8. Please refer to user manual for maximum operation ambient temperature.

**WARNING:**

Hazardous moving parts, keep fingers and other body parts away.

**CAUTION:**

(For equipment with RTC (CR2032) battery or rechargeable battery pack)

Risk of explosion if battery is replaced by an incorrect type.

Dispose of used batteries according to the Instructions as below.

1. DO NOT throw the battery in fire.
2. DO NOT short circuit the contacts.
3. DO NOT disassemble the battery.
4. DO NOT throw the battery in municipal waste.
5. The symbol of the crossed out wheeled bin indicates that the battery should not be placed in municipal waste.



**Caution:** The printhead may be hot and could cause severe burns. Allow the printhead to cool.

**CAUTION:**

Any changes or modifications not expressly approved by the grantee of this device could void the user's authority to operate the equipment.

**CE Statement:**

This equipment complies with EU radiation exposure limits set forth for an uncontrolled environment. This equipment should be installed and operated with minimum distance 20 cm between the radiator & your body.

All operational modes:



2.4GHz: 802.11b, 802.11g, 802.11n (HT20), 802.11n (HT40)

5GHz: 802.11a,

The frequency, mode and the maximum transmitted power in EU are listed below:

2400 MHz – 2483.5 MHz: 19.88 dBm (EIRP)

5150 MHz – 5250 MHz: 17.51 dBm (EIRP)

5150-5350MHz for Only indoor use

5470-5725MHz for indoor/outdoor use

### Restrictions In AZE

National restrictions information is provided below

Frequency Band	Country	Remark
5150-5350MHz	Azerbaijan	No license needed if used indoor and power not exceeding 30mW
5470-5725MHz		

Hereby, TSC Auto ID Technology Co., Ltd. declares that the radio equipment type [Wi-Fi] IEEE 802.11 a/b/g/n is in compliance with Directive 2014/53/EU

The full text of the EU declaration of conformity is available at the following internet address: [http:// www.tscprinters.com](http://www.tscprinters.com)

### RF exposure warning (Wi-Fi)

This equipment must be installed and operated in accordance with provided instructions and must not be co-located or operating in conjunction with any other antenna or transmitter. End-users and installers must be providing with antenna installation instructions and transmitter operating conditions for satisfying RF exposure compliance.

SAR Value: 0.736 W/kg

### RF exposure warning (For Bluetooth)

The equipment complies with FCC RF exposure limits set forth for an uncontrolled environment.  
The equipment must not be co-located or operating in conjunction with any other antenna or transmitter.

### **Canada, Industry Canada (IC) Notices**

This Class B digital apparatus complies with Canadian ICES-003 and RSS-210.

Operation is subject to the following two conditions: (1) this device may not cause interference, and (2) this device must accept any interference, including interference that may cause undesired operation of the device.

### **Radio Frequency (RF) Exposure Information**

The radiated output power of the Wireless Device is below the Industry Canada (IC) radio frequency exposure limits. The Wireless Device should be used in such a manner such that the potential for human contact during normal operation is minimized.

This device has been evaluated for and shown compliant with the IC Specific Absorption Rate (“SAR”) limits when installed in specific host products operated in portable exposure conditions. **(For Wi-Fi)**

This device has also been evaluated and shown compliant with the IC RF Exposure limits under portable exposure conditions. (Antennas are less than 20 cm of a person's body). **(For Bluetooth)**

### **Canada, avis de l'Industry Canada (IC)**

Cet appareil numérique de classe B est conforme aux normes canadiennes ICES-003 et RSS-210.

Son fonctionnement est soumis aux deux conditions suivantes : (1) cet appareil ne doit pas causer d'interférence et (2) cet appareil doit accepter toute interférence, notamment les interférences qui peuvent affecter son fonctionnement.

### **Informations concernant l'exposition aux fréquences radio (RF)**

La puissance de sortie émise par l'appareil sans fil est inférieure à la limite d'exposition aux fréquences radio de l'Industry Canada (IC). Utilisez l'appareil sans fil de façon à minimiser les contacts humains lors du fonctionnement normal.

Ce périphérique a été évalué et démontré conforme aux limites SAR (Specific Absorption Rate – Taux d'absorption spécifique) par

l'IC lorsqu'il est connecté à des dispositifs hôtes spécifiques opérant dans des conditions d'utilisation mobile. **(Pour le Wi-Fi)**

Ce périphérique a également été évalué et démontré conforme aux limites d'exposition radio-fréquence par l'IC pour des utilisations par des opérateurs mobiles (les antennes sont à moins de 20 cm du corps d'une personne). **(Pour le Bluetooth)**

### **NCC 警語:**

經型式認證合格之低功率射頻電機，非經許可，公司、商號或使用者均不得擅自變更頻率、加大功率或變更原設計之特性及功能。(即

低功率電波輻射性電機管理辦法第十二條)

低功率射頻電機之使用不得影響飛航安全及干擾合法通信；經發現有干擾現象時，應立即停用，並改善至無干擾時方得繼續使用。

前項合法通信，指依電信法規定作業之無線電通信。低功率射頻電機須忍受合法通信或工業、科學及醫療用電波輻射性電機設備之干

擾。(即低功率電波輻射性電機管理辦法第十四條)

### **警告使用者：**

此為甲類資訊技術設備，於居住環境中使用時，可能會造成射頻擾動，在此種情況下，使用者會被要求採取某些適當的對策。

設備名稱：可攜式熱感條碼印表機，主型號：Alpha-2R Series  
 Equipment name Type designation (Type)

單元Unit	限用物質及其化學符號 Restricted substances and its chemical symbols					
	鉛Lead (Pb)	汞Mercury (Hg)	鎘Cadmium (Cd)	六價鉻 Hexavalent chromium (Cr <sup>6+</sup> )	多溴聯苯 Polybrominated biphenyls (PBB)	多溴二苯醚 Polybrominated diphenyl ethers (PBDE)
內外塑膠件	○	○	○	○	○	○
內外鐵件	-	○	○	○	○	○
滾輪	○	○	○	○	○	○
電路板	-	○	○	○	○	○
晶片電阻	-	○	○	○	○	○
積層陶瓷表面黏 著電容	○	○	○	○	○	○
集成電路-IC	-	○	○	○	○	○
電源供應器	○	○	○	○	○	○
印字頭	○	○	○	○	○	○

插座	-	○	○	○	○	○
線材	-	○	○	○	○	○
<p>備考1. “超出0.1 wt %” 及 “超出0.01 wt %” 係指限用物質之百分比含量超出百分比含量基準值。</p> <p>Note 1 : “Exceeding 0.1 wt %” and “exceeding 0.01 wt %” indicate that the percentage content of the restricted substance exceeds the reference percentage value of presence condition.</p> <p>備考2. “○” 係指該項限用物質之百分比含量未超出百分比含量基準值。</p> <p>Note 2 : “○” indicates that the percentage content of the restricted substance does not exceed the percentage of reference value of presence.</p> <p>備考3. “-” 係指該項限用物質為排除項目。</p> <p>Note 3 : The “-” indicates that the restricted substance corresponds to the exemption.</p>						

## MFi for Bluetooth



Use of the Made for Apple badge means that an accessory has been designed to connect specifically to the Apple product(s) identified in the badge, and has been certified by the developer to meet Apple performance standards. Apple is not responsible for the operation of this device or its compliance with safety and regulatory standards.

## For US Model

Made for iPhone®XS Max, iPhone XS, iPhone XR, iPhone X, iPhone 8, iPhone 8 Plus, iPhone 7, iPhone 7 Plus, iPhone SE, iPhone 6s, iPhone 6s Plus, iPhone 6, iPhone 6 Plus, iPhone 5s, iPad Pro® 12.9-inch (2nd generation), iPad Pro 10.5-inch, iPad® (6th generation), iPad (5th generation), iPad Pro 9.7-inch, iPad Pro 12.9-inch (1st generation), iPad Air® 2,

iPad mini™ 4, iPad mini 3, iPad Air, iPad mini 2, iPod touch® (6th generation)

iPad, iPad Air, iPad Pro, iPhone are trademarks of Apple Inc., registered in the U.S. and other countries.

### For JP Model

Made for iPhone XS Max, iPhone XS, iPhone XR, iPhone X, iPhone 8, iPhone 8 Plus, iPhone 7, iPhone 7 Plus, iPhone SE, iPhone 6s, iPhone 6s Plus, iPhone 6, iPhone 6 Plus, iPhone 5s, iPad Pro 12.9-inch (2nd generation), iPad Pro 10.5-inch, iPad (6th generation), iPad (5th generation), iPad Pro 9.7-inch, iPad Pro 12.9-inch (1st generation), iPad Air 2, iPad mini 4, iPad mini 3, iPad Air, iPad mini 2, iPod touch (6th generation)

iPad, iPad Air, iPad Pro, iPhone are trademarks of Apple Inc., registered in the U.S. and other countries. The trademark “iPhone” is used in Japan with a license from Aiphone K.K.

### Except for US, JP Model

Made for iPhone XS Max, iPhone XS, iPhone XR, iPhone X, iPhone 8, iPhone 8 Plus, iPhone 7, iPhone 7 Plus, iPhone SE, iPhone 6s, iPhone 6s Plus, iPhone 6, iPhone 6 Plus, iPhone 5s, iPad Pro 12.9-inch (2nd generation), iPad Pro 10.5-inch, iPad (6th generation), iPad (5th generation), iPad Pro 9.7-inch, iPad Pro 12.9-inch (1st generation), iPad Air 2, iPad mini 4, iPad mini 3, iPad Air, iPad mini 2, iPod touch (6th generation)

iPad, iPad Air, iPad Pro, iPhone are trademarks of Apple Inc., registered in the U.S. and other countries.

# Revision History

Date	Content	Editor
2024/1/19	<ul style="list-style-type: none"><li>- Updated the printer specification</li><li>- Updated the ch. Power-on Utilities</li><li>- Updated the ch. TSC Console</li><li>- Updated the ch. Loading the Media</li><li>- Updated the LED Indication table</li><li>- Updated the Charge by Charger Station (Optional)</li></ul>	Camille



[www.tscprinters.com](http://www.tscprinters.com)